

Quick Setting Manual

快速設定手冊

TECO

INVERTER



TECO  **INVERTER**

E510s Series

Chapter 1 Safety Precautions

1.1 Before Power Up

Danger

- Make sure the main circuit connections are correct Single phase L1(L),L3(N), Three phase L1(L),L2,L3(N) are power-input terminals and must not be mistaken for T1,T2 and T3. Otherwise, inverter damage can result.

Caution

- The line voltage applied must comply with the inverter's specified input voltage.(See the nameplate)
- To avoid the front cover from disengaging, or other damage do not carry the inverter by its covers. Support the drive by the heat sink when transporting. Improper handling can damage the inverter or injure personnel and should be avoided.
- To avoid the risk of fire, do not install the inverter on a flammable object.Install on nonflammable objects such as metal
- This product provides the 10V/24V for internal use only, do not use as the power supply sources for other external components, such as sensors, electronic components ... etc., otherwise it will cause adverse situation.
- When disconnecting the remote keypad, turn the power off first to avoid any damage to the keypad or the inverter.

Caution

- This product is sold subject to EN 61800-3 and EN 61800-5-1. In a domestic environment this product may cause radio interference in which case the user may be required to apply corrective measures.
- This product offers motor over temperature protection function.

Caution

- Work on the device/system by unqualified personnel or failure to comply with warnings can result in severe personal injury or serious damage to material. Only suitably qualified personnel trained in the setup, installation, commissioning and operation of the product should carry out work on the device/system.
- Only permanently-wired input power connections are allowed.

1.2 During Power Up

Danger

- Always turn OFF the power supply before attempting inverter installation and wiring of the user terminals.
- Wiring must be performed by a qualified personnel / certified electrician.
- Make sure the inverter is properly grounded. (200V Class: Grounding impedance shall be less than 100Ω. 400V Class: Grounding impedance shall be less than 10Ω.) Please connect to the earth according to EN61800-5-1 standard request, For system 430, 440, 450, 460 and 470, wiring size must be at least 10mm²(8 AWG) only can comply the standard of leakage current.
- RCD is required to be in compliance with the protection norm of B-type leakage current.
- Please check and test emergency stop circuits after wiring. (Installer is responsible for the correct wiring.)
- Never touch any of the input or output power lines directly or allow any input of output power lines to come in contact with the inverter case.
- Do not perform a dielectric voltage withstand test (megger) on the inverter this will result in inverter damage to the semiconductor components.

Caution

- The line voltage applied must comply with the inverter's specified input voltage.
- Connect braking resistor and braking unit to the designated terminals.
- Do not connect a braking resistor directly to the DC terminals P (+) and N (-), otherwise fire may result.
- Use wire gauge recommendations and torque specifications.
- Never connect input power to the inverter output terminals U/T1, V/T2, W/T3.
- Do not connect a power factor correction capacitor or surge suppressor to the inverter output.
- Ensure the interference generated by the inverter and motor does not affect peripheral devices.

Danger

- When the momentary power loss is longer than 2 seconds, the inverter will not have sufficient stored power for its control circuit. Therefore, when the power is re-applied, the run operation of the inverter will be based on the setting value of parameter 00-02(or 00-03) and 07-04 status of external run switch.
- When the momentary power loss is shorter, inverter still can control the power. Therefore, when the power is re-applied, the run operation of inverter will be based on the setting value of parameter 07-00.
- When the power is re-applied, the run operation of inverter will be based on the setting value of 00- 02(or 00- 03), 07- 04 and the status of power and operation switch(FWD/REVswitch)(and 07- 00/07- 01/07- 02) :
 - (1) If the parameter 00-02(or 00- 03)=0, inverter will not start automatically when the power is re-applied.
 - (2) If the parameter 00- 02(or 00- 03)=1 and the power or operation switch is open, inverter will not start automatically when the power is re-applied.
 - (3) If 00- 02(or 00- 03)=1, then power and operation switch are open (07- 04=0), inverter will restart automatically when the power is re-applied.For the safety, please turn off the power and operation switch after powered off.
- For the safety, please read the function explanation from the manual.

1.3 Before Operation

Caution

- Make sure the inverter model and rating are the same as that set in parameter 13-00.
- Reduce the carrier frequency (parameter 11-01) if the cable from the inverter to the motor is greater than 80 ft (25m). A high-frequency current can be generated by stray capacitance between the cables and result in an overcurrent trip of the inverter, an increase in leakage current, or an inaccurate current readout

Caution

- When the power is applied, inverter will show the voltage rating on display for 2 seconds according to the setting value of parameter 01-14.
- Do not connect a load to the motor while performing a rotational auto-tune.
- Make sure it is safe to operate the inverter and motor before performing a rotational auto-tune.

1.4 During Operation

Danger

- Be sure to install all covers before turning on power
- Do not connect or disconnect the motor during operation. Otherwise, It may cause the inverter to trip or damage the unit.
- Please do not close to the equipment when the reset function is performed, equipment will restart the fault has been removed.
- Do not operate switches with wet hands, otherwise electric shock may result

- The motor will restart automatically after stop when auto-restart function is enabled. In this case, care must be taken while working around the drive and associated equipment.
- Confirm that no run command is active upon resetting the alarm or fault, otherwise accidents may occur.
- If automatic restart after power recovery (parameter 07-00) is enabled, the inverter will start automatically after power is restored
- Do not touch inverter terminals when energized even if inverter has stopped, otherwise electric shock may result.
- It is not permissible to open the equipment until 5 minutes after the power has been removed. ° (if the inverter rating is 15HP above, please open the equipment until 15 minutes after the power has been removed).

 **Caution**

- Do not touch heat-generating components such as heat sink and braking resistors.
- Carefully check the performance of motor or machine before operating at high speed, otherwise Injury may result.
- Note the parameter settings related to the braking unit when applicable.
- After the power is turned off, the cooling fan may continue to run for some time.
- Do not check signals on circuit boards while the inverter is running.

1.5 Maintenance, Inspection and Replacement

 **Warning**

- Wait a minimum of five minutes after power has been turned OFF before starting an inspection. Also confirm that the charge light is OFF and that the DC bus voltage has dropped below 25Vdc.
- Never touch high voltage terminals in the inverter.
- Make sure power to the inverter is disconnected before disassembling the inverter.
- Only authorized personnel should perform maintenance, inspection, and replacement operations. (Take off metal jewelry such as watches and rings and use insulated tools.)

 **Caution**

- The Inverter can be used in an environment with a temperature range from 14° ~104(°F) or -10~+50(°C1.6) and relative humidity of 95% non-condensing.
- The inverter must be operated in a dust, gas, mist and moisture free environment.
 - * -10°C~+50°C (suitable for the product which without dust cover or sticker)
 - * -10°C~+40°C (suitable for the product which with dust cover or sticker)

1.6 Disposal of the Inverter

 **Caution**

- Please dispose of this unit with care as an industrial waste and according to your required local regulations.
- The capacitors of inverter main circuit and printed circuit board are considered as hazardous waste and must not be burned.
- The Plastic enclosure and parts of the inverter such as the top cover board will release harmful gases if burned.



Equipment containing electrical components may not be disposed of together with domestic waste. It must be separately collected with electrical and electronic waste according to local and currently valid legislation.

1.7 Guaranteed Liability Exemption

- Loss of opportunity caused by the company's products, damage to customers of your company or your company, damage to non-company products, or compensation for other businesses, whether within the warranty period or not, is not covered by the company.

Chapter 2 Environment and Installation

2.1 System Diagram

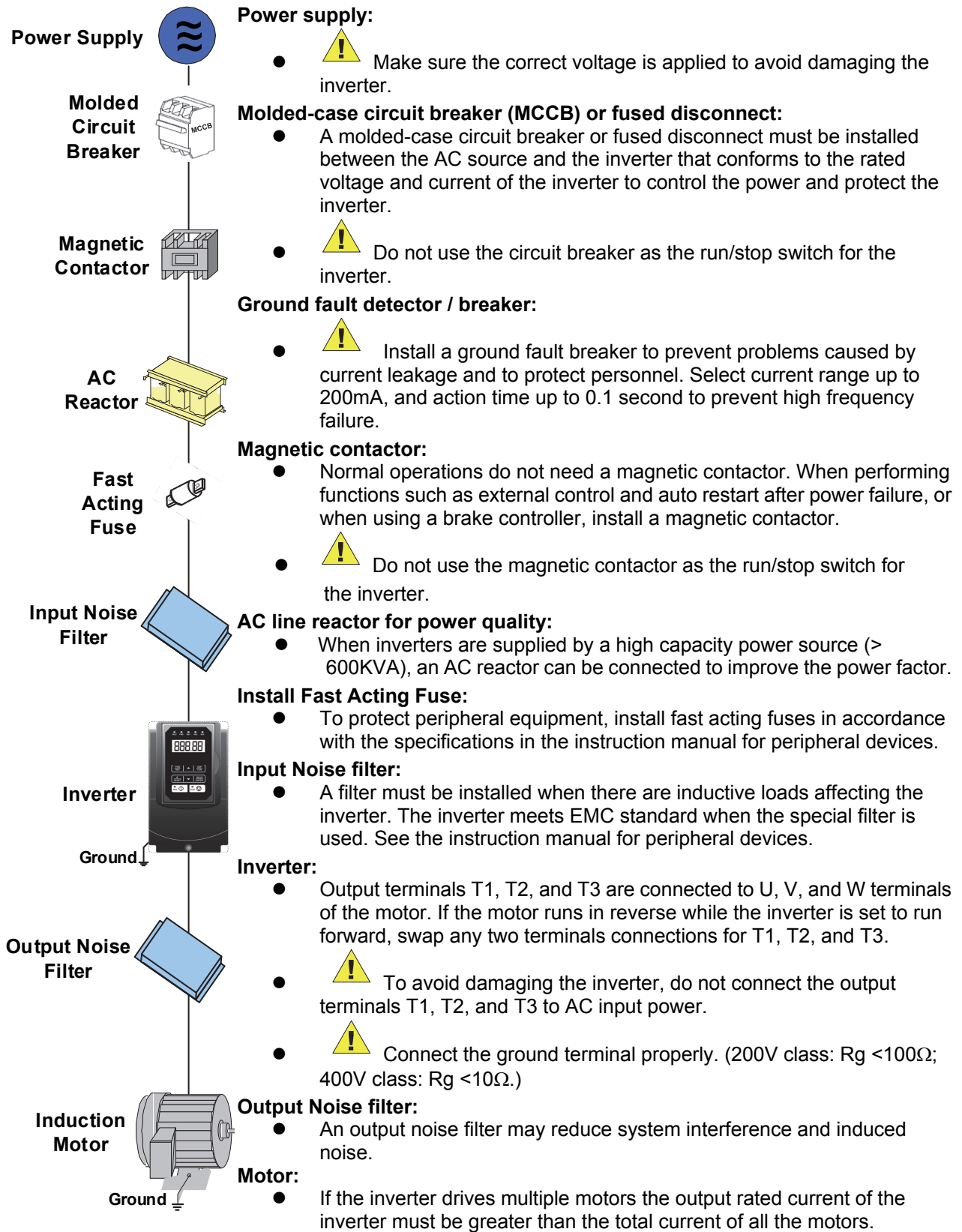

2.2 Standard Wiring

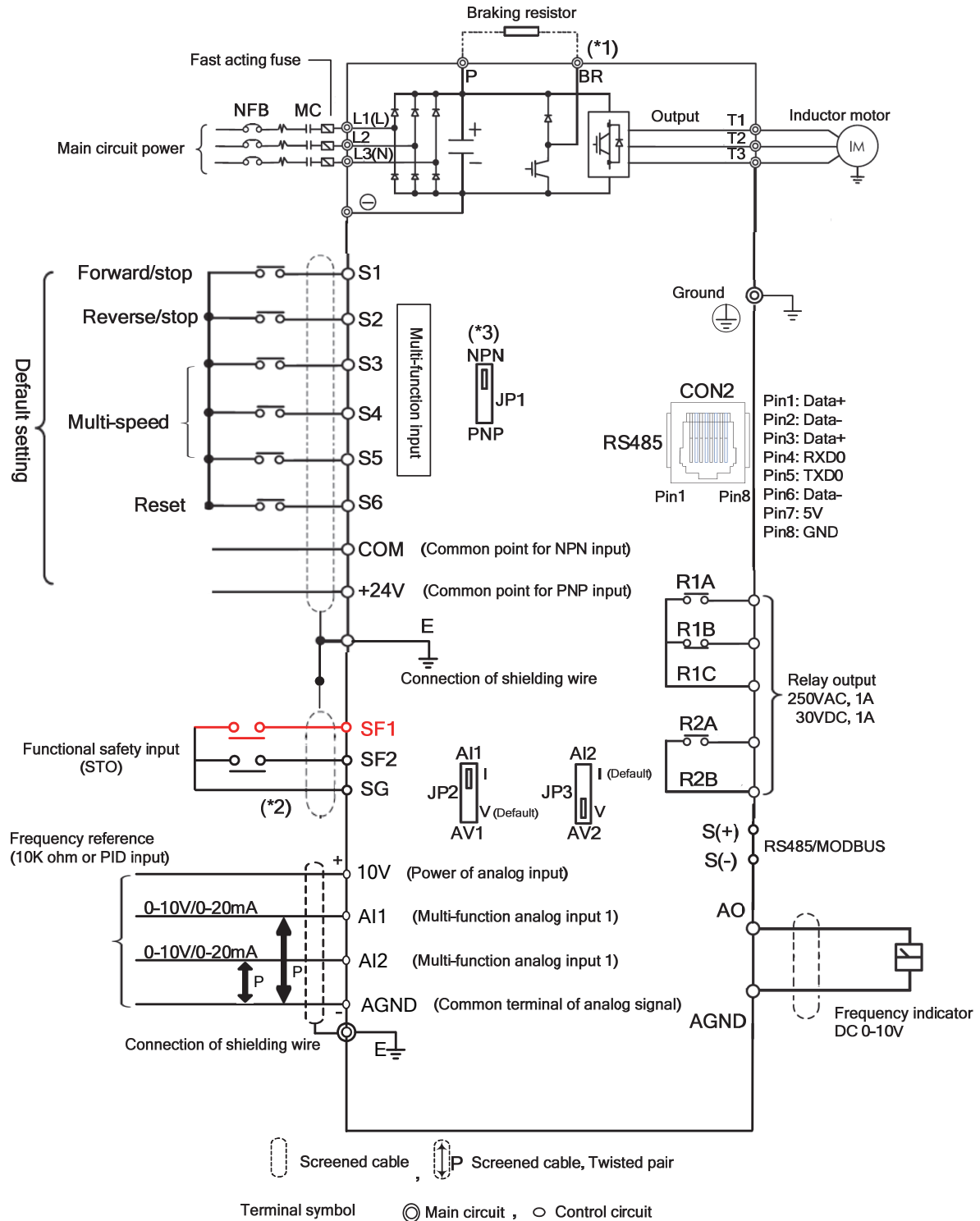

Remark

- (*1) Models 200V 0.5-25HP and 400V 1-40HP with built-in braking transistor, braking transistor can be connected directly between P and BR.
- (*2) Safety input connector (SF/SG) should be shorted so that inverter outputs properly. When the safety input is used, please be sure to remove the short-pin between SF/SG.
- (*3) The multi-function digital input terminals S1-S6 can be set to Sink(NPN) and Source(PNP) by JP1.

2.3 User Terminals

2.2.1 Power Terminals

Terminal symbol	TM1 function description	
L1(L)	Main power input,	Single phase : L1(L)/L3(N)
L2		Single/Three phase : L1(L)/L2/L3(N)
L3(N)		Three phase : L1/L2/L3
T1/T2/T3	Inverter output, connect to U/V/W terminals of motor	
P	Externally connected braking resistor (Please see the braking resistors reference on chapter 6)	
BR		
	Ground terminal	

2.2.2 Control Circuit Terminals

Control terminal :

R2A	R2B	R1A	R1B	R1C		S1	S3	S5	24V	AI1	AI2			
S(+)	S(-)	SF1	SG	SF2	COM	S2	S4	S6	AGND	10V	AO			

Description of control circuit terminal

Type	Terminal	Function	Signal Level
Digital input	S1	Please refer to group3 (digital input functions) for default setting and setting range.	24 VDC, 8 mA photocoupler isolation. (The max. input voltage is 30 Vdc, input resistance is 4.3kΩ) High Logic: 13V Low Logic: 10V
	S2		
	S3		
	S4		
	S5		
	S6		
Relay output	R1A	Normal Open	250VAC/1A (30VDC/1A)
	R1B	Normal Close	
	R1C	Common Point	
	R2A	Normal Open	
	R2B		
24V supply	24V	Common point of PNP input (JP1 switch to PNP)	±15%, Max. output current: 60mA
	COM	Common point of NPN input (JP1 switch to NPN)	
Analog input	10V	Built-in power for external potentiometer	10V (max current is 20mA)
	AI1/AV1	Multi-analog input 1 (0-10V/0-20mA) (Please use JP2 to select voltage or current input)	Resistance for voltage input is 153KΩ; for current input is :500Ω
	AI2/AV2	Multi-analog input 2 (0-10V/0-20mA) (Please use JP3 to select voltage or current input)	
	AGND	Analog input common point.	----
		Ground terminal.	----
Analog output	AO	Analog output terminal.	0 ~ 10V,(Max. Current: 2mA)
	AGND	Analog input common point.	----
STO Terminal	SF1,SF2	The default status of safety switch is normal close, when the terminal becomes to normal open status, output voltage of inverter will be cut off.	24V for SF1/SF2
	SG		
Modbus	S(+)	Modbus communication (Baud rate setting from 9600 to 38400)	
	S(-)		

Chapter 3 Keypad and Programming Functions

3.1 Parameters

Parameter group	Group Name
Group 00	Basic Parameters
Group 01	V/F Control Parameters
Group 02	IM Motor Parameters
Group 03	External Digital Input and Output Parameters
Group 04	External Analog Input and Output Parameters
Group 05	Multi-Speed Parameters
Group 06	Automatic Program Operation Parameters
Group 07	Start /Stop Parameters
Group 08	Protection Parameters
Group 09	Communication Parameters
Group 10	PID Parameters
Group 11	Auxiliary Parameters
Group 12	Monitoring Parameters
Group 13	Maintenance Parameters
Group 14	PLC Parameters
Group 15	PLC Monitoring Parameters
Group 16	LCD Parameters
Group 17	Automatic Tuning Parameters
Group 18	Slip Compensation Parameters
Group 20	Speed Control Parameters
Group 21	Torque And Position Control Parameters
Group 22	PM Motor Parameters
Group 23	Constant Pressure PUMP Parameters

Parameter Attribute	
*1	Parameters can be changed during run operation.
*2	Reserved
*3	Parameter will not reset to default during a factory reset (initialization).
*4	Read-only parameter
*5	Parameter will be displayed in being coupled with the option card.
*6	Parameter will be displayed only in LED keypad.
*7	Parameter will be displayed only in LCD keypad.
*8	When 13-08 setting is changed, the value will be also changed.

Group 00: Basic Parameters				
Code	Parameter Name	Setting Range	Default	Attribute
00-00	Control Mode Selection	0: V/F	0	*3
		2: SLV		
		5: PMSLV		
00-01	Motor's Rotation Direction	0: Forward	0	*1
		1: Reverse		
00-02	Main Run Command Source Selection	0: Keypad	1	
		1: External Terminal (Control Circuit)		
		2: Communication Control (RS-485)		
		3: PLC		
00-03	Alternative Run Command Selection	0: Keypad	0	
		1: External Terminal (Control Circuit)		
		2: Communication Control (RS-485)		
		3: PLC		
00-04	Operation Modes For External Terminals	0: Forward/ Stop-Reverse/ Stop	0	
		1: Run/Stop-Reverse/Forward		
		2: 3 Wire Control Mode Run/Stop		
00-05	Main Frequency Command Source Selection	0: UP/DOWN of Keypad	2	
		1: Potentiometer on Keypad		
		2: External AI1 Analog Signal Input		
		3: External AI2 Analog Signal Input		
		4: External Up/Down Frequency		
		5: Communication Setting Frequency		
		6: Reserved		
		7: Pulse Input (*6)		
00-06	Alternative Frequency Command Source Selection	0: UP/DOWN of Keypad	0	
		1: Potentiometer on Keypad		
		2: External AI1 Analog Signal Input		
		3: External AI2 Analog Signal Input		
		4: External Up/Down Frequency		
		5: Communication Setting Frequency		
		6: Reserved		

Group 00: Basic Parameters				
Code	Parameter Name	Setting Range	Default	Attribute
		7: Pulse Input (*6)		
00-07	Main and Alternative Frequency Command Modes	0: Main or Alternative Frequency	0	
		1: Main Frequency+ Alternative Frequency		
00-08	Communication Frequency Command	0.00~599.00	0.00	*4
00-09	Frequency Command Save on Power Down	0: Disable	0	
		1: Enable		
00-10	Initial Frequency Selection (keypad mode)	0: by Current Frequency Command	0	
		1: by 0 Frequency Command		
		2: by 00-11		
00-11	Initial Frequency Setpoint	0.00-599.00	50/60	*1
00-12	Frequency Upper Limit	0.01-599.00	0.0	
00-13	Frequency Lower Limit	0.00-599.00	0.0	
00-14	Acceleration Time 1	0.1~6000.0	*	*1
00-15	Deceleration Time 1	0.1~6000.0	*	*1
00-16	Acceleration Time 2	0.1~6000.0	*	*1
00-17	Deceleration Time 2	0.1~6000.0	*	*1
00-18	Jog Frequency	0.00~599.00	2.00	*1
00-19	Jog Acceleration Time	0.1~0600.0	*	*1
	Jog Deceleration Time	0.1~0600.0	*	*1
00-20	Jog Deceleration Time	0.1~0600.0	*	*1
00-21	Acceleration Time 3	0.1~6000.0	*	*1
00-22	Deceleration Time 3	0.1~6000.0	*	*1
00-23	Acceleration Time 4	0.1~6000.0	*	*1
00-24	Deceleration Time 4	0.1~6000.0	*	*1
00-26	Emergency Stop Time	0.1~6000.0	5.0	
00-27	HD/ND Mode	0: HD (Heavy Duty Mode)	0	*3

Group 00: Basic Parameters				
Code	Parameter Name	Setting Range	Default	Attribute
	(F5/F6 Only)(***)	1: ND (Normal Duty Mode)		
00-34	Language	0: English 1: Simplified Chinese 2: Traditional Chinese 3: Turkish	0	*7
00-35	Minimum Frequency Detection	0: Alarm 1: Keep Running At Lower Frequency	0	
00-36	PID Lower Frequency Selection	0: Disable (Lower Frequency of PID Sleep Mode) 1: Enable (0Hz of PID Sleep Mode)	0	

* : Refer to the following attachment 1

*** : If parameter 00-27 is set to ND mode, group 02 motor 1 parameter will automatically adjust to more than 1 class of it.

If parameter 00-27 is set to HD mode, group 02 motor 1 parameter will automatically adjust to the same class of it.

It is suggested that parameter 00-27 be set first before motor performs auto-tuning because the parameter will make the motor parameter automatically be changed.

Group 01: V/F Control Parameters				
Code	Parameter Name	Setting Range	Default	Attribute
01-00	Volts/Hz Patterns	0~FF	F	*3
01-02	Maximum Output Frequency of Motor 1	4.8~599.0	50.0/60.0	*8
01-03	Maximum Output Voltage of Motor 1	200V: 0.1~255.0 400V: 0.2~510.0	230.0 400.0	*8
01-04	Middle Output Frequency 2 of Motor 1	0.0~599.0	0.0	
01-05	Middle Output Voltage 2 of Motor 1	200V: 0.0~255.0 400V: 0.0~510.0	0.0	*8
01-06	Middle Output Frequency 1 of Motor 1	0.0~599.0	2.5/3.0	*8
01-07	Middle Output Voltage 1 of	200V: 0.0~255.0	KVA	*8

Group 01: V/F Control Parameters				
Code	Parameter Name	Setting Range	Default	Attribute
	Motor 1	400V: 0.0~510.0		
01-08	Minimum Output Frequency of Motor 1	0.0~599.0	V/F : 1.3/1.5 SLV : 0.5/0.6 PMSL V : 10.0	
01-09	Minimum Output Voltage of Motor 1	200V: 0.0~255.0 400V: 0.0~510.0	*	*8
01-10	Torque Compensation Gain	0.0~2.0	0.5	*1
01-11	Selection of Torque Compensation Mode	0: Mode 0 (Normal) 1: Mode 1 (High Speed)	0	
01-12	Base Frequency of Motor 1	4.8~599.0	50.0/60.0	*8
01-13	Base Output Voltage of Motor 1	200V: 0.0~255.0 400V: 0.0~510.0	230.0 400.0	*8
01-14	Input Voltage Setting	200V: 55.0~255.0 400V: 10.0~510.0	230.0 400.0	*8
01-15	Torque Compensation Time	0~10000	200	
01-16	Maximum Output Frequency of Motor 2	4.8~599.0	50.0/60.0	*8
01-17	Maximum Output Voltage of Motor 2	200V: 0.1~255.0 400V: 0.2~510.0	230.0 400.0	*8
01-18	Middle Output Frequency 2 of Motor 2	0.0~599.0	0.0	
01-19	Middle Output Voltage 2 of Motor 2	200V: 0.0~255.0 400V: 0.0~510.0	0.0	
01-20	Middle Output Frequency 1 of Motor 2	0.0~599.0	2.5/3.0	*8
01-21	Middle Output Voltage 1 of Motor 2	200V: 0.0~255.0 400V: 0.0~510.0	KVA	*8
01-22	Minimum Output Frequency of Motor 2	0.0~599.0	1.3/1.5	
01-23	Minimum Output	200V: 0.0~255.0	KVA	*8

Group 01: V/F Control Parameters				
Code	Parameter Name	Setting Range	Default	Attribute
	Voltage of Motor 2	400V: 0.0~510.0		
01-24	Base Frequency of Motor 2	4.8~599.0	50.0/60.0	*8
01-25	Base Output Voltage of Motor 2	200V: 0.0~255.0	230.0	*8
		400V: 0.0~510.0	400.0	
01-26	V/F Curve Selection of Motor 2	0~FF	F	*3

Group 02: IM Motor Parameters				
Code	Parameter Name	Setting Range	Default	Attribute
02-00	No-Load Current of Motor1	0.01~600.00	KVA	
02-01	Rated Current of Motor1	Bottom limit : 10% Inverter rated current (V/F) 25% Inverter rated current (SLV) Upper limit : Based on inverter capacity	KVA	
02-03	Rated Rotation Speed of Motor1	0~60000	KVA	*8
02-04	Rated Voltage of Motor1	200V: 50.0~240.0	230.0	*8
		400V: 100.0~480.0	400.0	
02-05	Rated Power of Motor1	0.01~600.00	-	
02-06	Rated Frequency of Motor1	4.8~599.0	50.0 / 60.0	*8
02-07	Poles of Motor 1	2~16 (Even)	4	
02-09	Excitation Current of Motor 1	15%~70% of Motor Rated Current	KVA	
02-10	Core Saturation Coefficient 1	1~100	KVA	
02-11	Core Saturation Coefficient 2 of Motor 1	1~100	KVA	

Group 02: IM Motor Parameters				
Code	Parameter Name	Setting Range	Default	Attribute
02-12	Core Saturation Coefficient 3 of Motor 1	80~300	KVA	
02-13	Core loss of Motor 1	0.0~15.0	KVA	
02-15	Resistance Between Wires of Motor 1	1~60.000	KVA	
02-16	Rotor Resistance Gain of Motor 1	1~60.000	KVA	
02-17	Leakage Inductance of Motor 1	0.001~60.000	KVA	
02-19	No-Load Voltage of Motor 1	200V: 50~240	-	*8
		400V: 100~480	-	
02-20	No-Load Current of Motor 2	0.01~600.00	KVA	
02-21	Rated Current of Motor 2	10%~200% of inverter rated current	KVA	
02-22	Rated Rotation Speed of Motor 2	0~60000	KVA	*8
02-23	Rated Voltage of Motor 2	200V: 50.0~240.0	230.0	*8
		400V: 100.0~480.0	400.0	
02-24	Rated Power of Motor 2	0.01~600.00	KVA	
02-25	Rated Frequency of Motor 2	4.8~599.0	50.0 / 60.0	*8
02-26	Poles of Motor 2	2~16(Even)	4	
02-32	Resistance between Wires of Motor 2	0.001~60.000	KVA	
02-33	Proportion of Motor Leakage Inductance	0.1~15.0	KVA	
02-34	Slip Frequency of Motor	0.10~20.00	KVA	

Group 03: External Digital Input and Output Parameters				
Code	Parameter Name	Setting Range	Default	Attribute
03-00	Multifunction Input Terminal S1	0: Forward/ Stop Command	0	
		1: Reverse/ Stop Command		
		2: Multi-Speed/ Position Setting Command 0		
		3: Multi-Speed/ Position Setting Command 1		
		4: Multi-Speed/ Position Setting Command 2		
		5: Multi-Speed/ Position Setting Command 3		
03-01	Multifunction Input Terminal S2	6: Forward Jog Run Command	1	
		7: Reverse Jog Run Command		
		8: UP Frequency Increasing Command		
		9: DOWN Frequency Decreasing Command		
		10: Acceleration / Deceleration Time Selection 2		
		11: Inhibit Acceleration/ Deceleration Command		
03-02	Multifunction Input Terminal S3	12: Main/ Alternative Run Switch Function	2	
		13: Main/ Alternative Frequency Switch Function		
		14: Emergency Stop (decelerate to zero and stop)		
		15: External Baseblock Command (rotation freely to stop)		
		16: PID Control Disable		
		17: Fault Reset		

Group 03: External Digital Input and Output Parameters				
Code	Parameter Name	Setting Range	Default	Attribute
		18: Auto Run Mode Enable		
		19: Speed Search 1		
		20: Energy Saving (V/F only)		
03-03	Multifunction Input Terminal S4	21: Reset PID integral value to Zero t	3	
		22: Counter Input		
		23: Counter reset		
		24: PLC Input		
		25: Pulse-In width measure(S3)		
		26: Pulse-In frequency measure(S3)		
03-04	Multifunction Input Terminal S5	27: Local/ Remote Selection	4	
		28: Remote Mode Selection		
		29: Jog Frequency Selection		
		33: DC Braking		
03-05	Multifunction Input Terminal S6	34: Speed Search 2	17	
		40: Switching between Motor 1/ Motor 2		
		41: PID Sleep		
		47: Fire mode		
		48: KEB Acceleration		
		57: Forced Frequency Run		
		63: Switch to Constant Pressure 2		
		65: Short-circuit Braking		
		66: PID Control Disable 2		
		68: External Fault		
69: External Overload				
03-06	Up/Down frequency step	0.00~5.00		

Group 03: External Digital Input and Output Parameters				
Code	Parameter Name	Setting Range	Default	Attribute
03-07	Up/Down Keep Frequency Status after Stop Command	0 : When Up/Down is used, the preset frequency is held as the inverter stops, and the UP/Down function is disabled	0	
		1 : When Up/Down is used, the preset frequency is reset to 0 Hz as the inverter stops.		
		2 : When Up/Down is used, the preset frequency is held as the inverter stops, and the UP/Down is available.		
		3 : When acceleration is used, the output frequency will be updated.		
03-08	S1~S8 DI Scan Time	1~200	1	
03-09	Multi-Function Terminal S1-S4 Type Selection	xxx0b:S1 A Contact	0000b	
		xxx1b:S1 B Contact		
		xx0xb:S2 A Contact		
		xx1xb:S2 B Contact		
		x0xxb:S3 A Contact		
03-10	Multi-Function Terminal S5~S6 type selection	x1xxb:S3 B Contact	0000b	
		0xxxb:S4 A Contact		
		1xxxb:S4 B Contact		
		xxx0b:S5 A Contact		
		xxx1b:S5 B Contact		

Group 03: External Digital Input and Output Parameters				
Code	Parameter Name	Setting Range	Default	Attribute
		xx0xb:S6 A Contact		
		xx1xb:S6 B Contact		
03-11	Relay (R1A-R1C) Output	0: During Running	1	
		1: Fault Contact Output		
		2: Frequency Agree		
		3: Setting Frequency Agree (03-13±03-14)		
		4: Frequency Detection 1(≥ 03-13+03-14)		
		5: Frequency Detection 2(≤ 03-13+03-14)		
		6: Automatic Restart		
		7: Momentary AC Power Loss		
		8: Rapid Stop		
		9: Base block		
		10: Motor Overload Protection (OL1)		
		11: Drive Overload Protection (OL2)		
		12: Over-torque Threshold Level (OT)		
		13: Preset Output Current Reached		
		14: Brake Control		
		15: PID Feedback Signal Loss		
		16: Single pre-set count (3-22~23)		
		17: Dual pre-set count (3-22~23)		
		18: PLC Status Indicator (00-02)		
		19: PLC Control*		
		20: Zero Speed		

Group 03: External Digital Input and Output Parameters				
Code	Parameter Name	Setting Range	Default	Attribute
		30: Motor 2 Selection 37: Detection Output of PID Feedback Loss		
03-12	Relay (R2A-R2B) Output	54: Turn on short-circuit braking 55: Low Current Detection 59: OH Detection	0	
03-13	Frequency Detection Level	0.0~599.0	0.0	
03-14	Frequency Detection Width	0.1~25.5	2.0	
03-15	Current Agree Level	0.1~999.9	0.1	
03-16	Delay Time of Current Agree Detection	0.1~10.0	0.1	
03-17	*Mechanical Braking Release Level	0.00~20.00	0.00	
03-18	*Mechanical Braking Level Set	0.00~20.00	0.00	
03-19	Relay (R1A-R2B) Type	xxx0b: R1 A Contact xxx1b: R1 B Contact xx0xb: R2 A Contact xx1xb: R2 B Contact	0000b	
03-20	Internal / External Multi-function Input Terminal Selection	0~63	0	
03-21	Action To Set The Internal Multi-Function Input Terminals	0~65	0	
03-22	Pre-Set Count 1	0~9999	0	
03-23	Pre-Set Count 2	0~9999	0	
03-24	Output Under Current Detection	0: Invalid 1: Valid	0	

Group 03: External Digital Input and Output Parameters				
Code	Parameter Name	Setting Range	Default	Attribute
03-25	Output Under Current Detection Level	0~999.9	0.1	
03-26	Output Under Current Detection Delay Time	0.0~655.34	0.01	
03-27	Pulse Frequency	50~25000	200	*1
03-28	Pulse Input Gain	0.0~1000.0	100.0	*1
03-29	Photo-coupler Output Selection	xxx0b: Photo-coupler A Contact xxx1b: Photo-coupler B Contact	0000b	
03-30	Selection of Pulse Input	0: General 1: PWM 2: PLC Encoder input	0	
03-33	Pulse Input Bias	-100.0~100.0	0.0	*1
03-34	Filter Time of Pulse Input	0.00~2.00	0.1	*1
03-53	Current Agree Level2	0.0~999.9	0.1	
03-54	Emergency Stop Action	Run command disable and emergency Stop command disable. 0: Restart after Inverter Stop 1: Restart after External Reset Command	0	

* : If the maximum output frequency of motor is over 300HZ, the frequency resolution is changed to 0.1Hz.

Group 04: External Analog Input and Output Parameters				
Code	Parameter Name	Setting Range	Default	Attribute
04-00	Analog Input Signal Type	0: AI1:0~10V AI2: 0~10V / 0~20mA 1: AI1:0~10V AI2: 4~20mA / 2~10V 2: AI1 2~10V AI2 0~10V / 0~20mA	1	

Group 04: External Analog Input and Output Parameters

Code	Parameter Name	Setting Range	Default	Attribute
		3: AI1 2~10V AI2 4~20mA / 2~10V		
04-01	AI1 Signal Scanning and Filtering Time	0.00~2.00	0.03	
04-02	AI1 Gain	0.0~1000.0	100.0	*1
04-03	AI1 Bias	-100.0~100.0	0	*1
04-05	AI1 Slope	0: Positive 1: Negative	0	
04-06	AI2 Signal Scanning and Filtering Time	0.00~2.00	0.03	
04-07	AI2 Gain	0.0~1000.0	100.0	*1
04-08	AI2 Bias	-100.0~100.0	0	*1
04-10	AI2 Slope	0: Positive 1: Negative	0	
04-11	Analog Output (AO) Mode	0: Output Frequency	0	
		1: Frequency Command		
		2: Output Voltage		
		3: DC Bus Voltage		
		4: Output Current		
04-12	AO Gain	0.0~1000.0	100.0	*1
04-13	AO Bias	-100.0~100.0	0	*1
04-15	AO Slope	0: Positive 1: Negative	0	
04-16	F-Gain	0: Disable 1: Enable	0	
04-20	AO Signal Scanning and Filtering Time	0.00~0.50	0.00	*1
04-22	AO voltage correction	0: Disable 1: Enable	0	

Group 05: Multi-Speed Parameters

Code	Parameter Name	Setting Range	Default	Attribute
05-00	Preset Speed Control Mode Selection	0 : Accel/Decel 1~4 apply to all speeds 1 : Individual Accel/Decel for each preset speed	0	
05-01	* Preset Speed 0	0.00~599.00	5.00	*1
05-02	* Preset Speed 1	0.00~599.00	5.00	*1
05-03	* Preset Speed 2	0.00~599.00	10.00	*1
05-04	* Preset Speed 3	0.00~599.00	20.00	*1

Group 05: Multi-Speed Parameters

Code	Parameter Name	Setting Range	Default	Attribute
05-05	* Preset Speed 4	0.00~599.00	30.00	*1
05-06	* Preset Speed 5	0.00~599.00	40.00	*1
05-07	* Preset Speed 6	0.00~599.00	50.00	*1
05-08	* Preset Speed 7	0.00~599.00	50.00	*1
05-09	* Preset Speed 8	0.00~599.00	5.00	*1
05-10	* Preset Speed 9	0.00~599.00	5.00	*1
05-11	* Preset Speed 10	0.00~599.00	5.00	*1
05-12	* Preset Speed 11	0.00~599.00	5.00	*1
05-13	* Preset Speed 12	0.00~599.00	5.00	*1
05-14	* Preset Speed 13	0.00~599.00	5.00	*1
05-15	* Preset Speed 14	0.00~599.00	5.00	*1
05-16	* Preset Speed 15	0.00~599.00	5.00	*1
05-17	Preset Speed 0-Acc time	0.1~6000.0	10.0	
05-18	Preset Speed 0-Dec time	0.1~6000.0	10.0	
05-19	Preset Speed 1-Acc time	0.1~6000.0	10.0	
05-20	Preset Speed 1-Dec time	0.1~6000.0	10.0	
05-21	Preset Speed 2-Acc time	0.1~6000.0	10.0	
05-22	Preset Speed 2-Dec time	0.1~6000.0	10.0	
05-23	Preset Speed 3-Acc time	0.1~6000.0	10.0	
05-24	Preset Speed 3-Dec time	0.1~6000.0	10.0	
05-25	Preset Speed 4-Acc time	0.1~6000.0	10.0	
05-26	Preset Speed 4-Dec time	0.1~6000.0	10.0	
05-27	Preset Speed 5-Acc time	0.1~6000.0	10.0	
05-28	Preset Speed 5-Dec time	0.1~6000.0	10.0	
05-29	Preset Speed 6-Acc time	0.1~6000.0	10.0	
05-30	Preset Speed 6-Dec time	0.1~6000.0	10.0	
05-31	Preset Speed 7-Acc time	0.1~6000.0	10.0	
05-32	Preset Speed 7-Dec time	0.1~6000.0	10.0	
05-33	Preset Speed 8-Acc time	0.1~6000.0	10.0	
05-34	Preset Speed 8-Dec time	0.1~6000.0	10.0	
05-35	Preset Speed 9-Acc time	0.1~6000.0	10.0	
05-36	Preset Speed 9-Dec time	0.1~6000.0	10.0	
05-37	Preset Speed 10-Acc time	0.1~6000.0	10.0	

Group 05: Multi-Speed Parameters				
Code	Parameter Name	Setting Range	Default	Attribute
05-38	Preset Speed 10-Dec time	0.1~6000.0	10.0	
05-39	Preset Speed 11-Acc time	0.1~6000.0	10.0	
05-40	Preset Speed 11-Dec time	0.1~6000.0	10.0	
05-41	Preset Speed 12-Acc time	0.1~6000.0	10.0	
05-42	Preset Speed 12-Dec time	0.1~6000.0	10.0	
05-43	Preset Speed 13-Acc time	0.1~6000.0	10.0	
05-44	Preset Speed 13-Dec time	0.1~6000.0	10.0	
05-45	Preset Speed 14-Acc time	0.1~6000.0	10.0	
05-46	Preset Speed 14-Dec time	0.1~6000.0	10.0	
05-47	Preset Speed 15-Acc time	0.1~6000.0	10.0	
05-48	Preset Speed 15-Dec time	0.1~6000.0	10.0	

* If the maximum output frequency of motor is over 300HZ, the frequency resolution is changed to 0.1Hz.

Group 06: Automatic Program Operation Parameters				
Code	Parameter Name	Setting Range	Default	Attribute
06-00	Auto Run Mode Selection	0: Disable	0	
		1: Execute a single cycle operation mode. Restart speed is based on the previous stopped speed.		
		2: Execute continuous cycle operation mode. Restart speed is based on the previous stopped speed.		
		3: After the completion of a single cycle, the on-going operation speed is based on the speed of the last stage. Restart speed is based on the previous stopped speed.		
		4: Execute a		

Group 06: Automatic Program Operation Parameters				
Code	Parameter Name	Setting Range	Default	Attribute
		single cycle operation mode. Restart speed will be based on the speed of stage 0.		
		5: Execute continuous cycle operation mode. Restart speed will be based on the speed of stage 0.		
		6: After the completion of a single cycle, the on-going operation speed is based on the speed of the last stage. Restart speed is based on the speed of stage 0.		
06-01	*Frequency Setting of Operation-Stage 1	0.00~599.00	0.0	*1
06-02	*Frequency Setting of Operation-Stage 2	0.00~599.00	0.0	*1
06-03	*Frequency Setting of Operation-Stage 3	0.00~599.00	0.0	*1
06-04	*Frequency Setting of Operation-Stage 4	0.00~599.00	0.0	*1
06-05	*Frequency Setting of Operation-Stage 5	0.00~599.00	0.0	*1
06-06	*Frequency Setting of Operation-Stage 6	0.00~599.00	0.0	*1
06-07	*Frequency Setting of Operation-Stage 7	0.00~599.00	0.0	*1
06-08	*Frequency Setting of Operation-Stage 8	0.00~599.00	0.0	*1

Group 06: Automatic Program Operation Parameters				
Code	Parameter Name	Setting Range	Default	Attribute
06-09	*Frequency Setting of Operation-Stage 9	0.00~599.00	0.0	*1
06-10	*Frequency Setting of Operation-Stage 10	0.00~599.00	0.0	*1
06-11	*Frequency Setting of Operation-Stage 11	0.00~599.00	0.0	*1
06-12	*Frequency Setting of Operation-Stage 12	0.00~599.00	0.0	*1
06-13	*Frequency Setting of Operation-Stage 13	0.00~599.00	0.0	*1
06-14	*Frequency Setting of Operation-Stage 14	0.00~599.00	0.0	*1
06-15	*Frequency Setting of Operation-Stage 15	0.00~599.00	0.0	*1
06-16	Operation Time Setting of Speed-Stage 0	0.0~6000.0	0.0	*1
06-17	Operation Time Setting of Speed-Stage 1	0.0~6000.0	0.0	*1
06-18	Operation Time Setting of Speed-Stage 2	0.0~6000.0	0.0	*1
06-19	Operation Time Setting of Speed-Stage 3	0.0~6000.0	0.0	*1
06-20	Operation Time Setting of Speed-Stage 4	0.0~6000.0	0.0	*1
06-21	Operation Time Setting of Speed-Stage 5	0.0~6000.0	0.0	*1
06-22	Operation Time Setting of Speed-Stage 6	0.0~6000.0	0.0	*1
06-23	Operation Time Setting of Speed-Stage 7	0.0~6000.0	0.0	*1
06-24	Operation Time Setting of Speed-Stage 8	0.0~6000.0	0.0	*1
06-25	Operation Time Setting of Speed-Stage 9	0.0~6000.0	0.0	*1
06-26	Operation Time Setting of Speed-Stage 10	0.0~6000.0	0.0	*1

Group 06: Automatic Program Operation Parameters				
Code	Parameter Name	Setting Range	Default	Attribute
06-27	Operation Time Setting of Speed-Stage 11	0.0~6000.0	0.0	*1
06-28	Operation Time Setting of Speed-Stage 12	0.0~6000.0	0.0	*1
06-29	Operation Time Setting of Speed-Stage 13	0.0~6000.0	0.0	*1
06-30	Operation Time Setting of Speed-Stage 14	0.0~6000.0	0.0	*1
06-31	Operation Time Setting of Speed-Stage 15	0.0~6000.0	0.0	*1
06-32	Operation Direction Selection of Speed-Stage 0	0: Stop 1: Forward 2: Reverse	0	
06-33	Operation Direction Selection of Speed-Stage 1	0: Stop 1: Forward 2: Reverse	0	
06-34	Operation Direction Selection of Speed-Stage 2	0: Stop 1: Forward 2: Reverse	0	
06-35	Operation Direction Selection of Speed-Stage 3	0: Stop 1: Forward 2: Reverse	0	
06-36	Operation Direction Selection of Speed-Stage 4	0: Stop 1: Forward 2: Reverse	0	
06-37	Operation Direction Selection of Speed-Stage 5	0: Stop 1: Forward 2: Reverse	0	
06-38	Operation Direction Selection of Speed-Stage 6	0: Stop 1: Forward 2: Reverse	0	
06-39	Operation Direction Selection of Speed-Stage 7	0: Stop 1: Forward 2: Reverse	0	
06-40	Operation Direction Selection of Speed-Stage 8	0: Stop 1: Forward 2: Reverse	0	
06-41	Operation Direction Selection of Speed-Stage 9	0: Stop 1: Forward 2: Reverse	0	
06-42	Operation Direction Selection of Speed-Stage 10	0: Stop 1: Forward 2: Reverse	0	

Group 06: Automatic Program Operation Parameters				
Code	Parameter Name	Setting Range	Default	Attribute
06-43	Operation Direction Selection of Speed-Stage 11	0: Stop 1: Forward 2: Reverse	0	
06-44	Operation Direction Selection of Speed-Stage 12	0: Stop 1: Forward 2: Reverse	0	
06-45	Operation Direction Selection of Speed-Stage 13	0: Stop 1: Forward 2: Reverse	0	
06-46	Operation Direction Selection of Speed-Stage 14	0: Stop 1: Forward 2: Reverse	0	
06-47	Operation Direction Selection of Speed-Stage 15	0: Stop 1: Forward 2: Reverse	0	

* If the maximum output frequency of motor is over 300Hz, the frequency resolution is changed to 0.1Hz.

Group 07: Start /Stop Parameters				
Code	Parameter Name	Setting Range	Default	Attribute
07-00	Momentary Power Loss and Restart	0: Disable	0	
		1: Enable		
07-01	Fault Reset Time	0~7200	0	
07-02	Number of Auto Restart Attempts	0~10	0	
07-03	Reset Mode Setting	0 : Enable Reset Only when Run Command is Off	0	
		1 : Enable Reset when Run Command is On or Off		
07-04	Momentary Power Loss and Restart	0: Enable Direct run on power up	1	
		1: Disable Direct run on power up		
07-05	Delay-ON Timer	1.0~300.0	1.0	
07-06	DC Injection Braking Start Frequency	0.0~10.0	1.5	
07-07	DC Injection Braking Level	0~100	50	

Group 07: Start /Stop Parameters				
Code	Parameter Name	Setting Range	Default	Attribute
	(Current Mode)			
07-08	DC Injection Braking Time	0.00~100.00	0.50	
07-09	Stop Mode Selection	0: Deceleration to Stop	0	
		1: Coast to Stop		
		2: DC Braking Stop in All Fields		
		3: Coast to Stop with Timer		
07-10	Speed Search Mode Selection	0: Normal Start 1: Execute Speed Search Once 2: Speed Search Start	0	
07-13	Low Voltage Detection Level	200V: 100~300	190	
		400V: 250~600	380	
07-15	DC Injection Brake Mode	0: Current Mode 1: Voltage Mode	1	
07-16	DC Injection Braking Time at Start	0.00~100.00	0.00	
07-18	Minimum Base block Time	0.1~5.0	KVA	
07-19	Speed Direction Search Operation Current	0~100	50	
07-20	Speed Search Operating Current	0~100	20	
07-21	Integral Time of Speed Searching	0.1~10.0	2.0	
07-22	Delay Time of Speed Searching	0.0~20.0	0.2	
07-23	Voltage Recovery Time	0.1~5.0	2.0	
07-24	Direction-Detection Speed Search Selection	0: Invalid	1	
		1: Valid		
07-25	Low Voltage Detection Time	0.00~1.00	0.02	
07-26	Start-up Mode Selection of	0: Start with speed	0	

Group 07: Start /Stop Parameters				
Code	Parameter Name	Setting Range	Default	Attribute
	SLV Coast to Stop	search 1: Normal start		
07-27	Start Selection after Fault During SLV Mode	0: Start with speed search 1: Normal start	0	
07-28	Start after External BaseBlock	0: Start with speed search 1: Normal start	0	
07-29	Run Command Selection at the Action of DC Braking	0: Not Allowed to Run 1: Allowable to Run	0	
07-33	Start Frequency of Speed Search Selection	0: Maximum Output Frequency 1: Frequency Command	0	
07-34	Start short-circuit braking time	0.00~100.00	0.00	
07-35	Stop Short-circuit braking time	0.00~100.00	0.50	
07-36	Short-circuit braking current limited	0.0~200.0	100.0	
07-37	Pre-Excitation Time	0.00~10.00	2.00	
07-38	Pre-Excitation Level	50~200	100	
07-39	Short-Circuit Braking Time of PM Motor Speed Search Function	0.00~100.00	0.00	
07-40	DC Injection Braking Time of PM Motor Speed Search Function	0.00~100.00	0.00	
07-45	STP2 Function Selection	0: STP2 is enabled 1: STP2 is disabled	0	

* : If the maximum output frequency of motor is over 300Hz, the frequency resolution is changed to 0.1Hz.

Group 08: Protection Parameters				
Code	Parameter Name	Setting Range	Default	Attribute
08-00	Stall Prevention Function	xxx0b: Stall prevention is enabled in acceleration.	0000b	
		xxx1b: Stall prevention is disabled in acceleration.		
		xx0xb: Stall prevention is enabled in deceleration.		
		xx1xb: Stall prevention is disabled in deceleration.		
		x0xxb: Stall prevention is enabled in operation		
		x1xxb: Stall prevention is disabled in operation		
		0xxxb: Stall prevention in operation is based on deceleration time of speed-stage 1.		
		1xxxb: Stall prevention in operation is based on deceleration time of speed-stage 2.		
08-01	Stall Prevention Level During Acceleration	20~200	HD: 150 ND: 120	
08-02	Stall Prevention Level During Deceleration	200V: 330V~410V	385V 770V	
		400V: 660V~820V		
08-03	Stall Prevention Level During Run	30~200	HD:160 ND:120	
08-05	Selection for Motor Overload Protection (OL1)	xxx0b: Overload Protection is disabled.	0001b	
		xxx1b: Overload Protection is enabled.		
		xx0xb: Cold Start of Motor Overload		
		xx1xb: Hot		

Group 08: Protection Parameters				
Code	Parameter Name	Setting Range	Default	Attribute
		Start of Motor Overload x0xxb: Standard Motor x1xxb: Inverter Duty Motor 0xxxb: Reserved 1xxxb: Reserved		
08-06	Start-up Mode of Overload Protection Operation (OL1)	0: Stop Output after Overload Protection 1: Continuous Operation after Overload Protection.	0	
08-07	Cooling Fan Control	0: Auto (Depends on temp.) 1: Operate while in RUN Mode 2: Always Run 3: Stop Operation	1	
08-08	Auto Voltage Regulation (AVR)	0: Enable 1: Disable	0	
08-09	Selection of Input Phase Loss Protection	0: Disable 1: Enable	0	
08-10	Selection of Output Phase Loss Protection	0: Disable 1: Enable	0	
08-13	Selection of Over-Torque Detection	0: Over-Torque Detection is Disabled. 1: Start to Detect when Reaching the Set Frequency. 2: Start to Detect when the Operation is Begun.	0	
08-14	Selection of Over-Torque Operation	0: Deceleration to Stop when Over Torque is Detected. 1: Display Warning when Over Torque is Detected. Go on Operation. 2: Coast to Stop when Over Torque is	0	

Group 08: Protection Parameters				
Code	Parameter Name	Setting Range	Default	Attribute
		Detected		
08-15	Level of Over-Torque Detection	0~300	160	
08-16	Time of Over-Torque Detection	0.0~10.0	0.1	
08-17	Fire Mode	0: Disable 1: Enable	0	
08-21	Limit of Stall Prevention During Acceleration	1~100	50	
08-22	Stall Prevention Detection Time During Run	2~100	100	
08-23	Ground Fault (GF) Selection	0: Disable 1: Enable	0	
08-24	Operation Selection of External Fault	0: Deceleration to Stop 1: Coast to Stop 2: Continuous Operation	0	
08-25	Detection Selection of External Fault	0: Immediately Detect When the Power is Supplied 1: Start to Detect During Operation	0	
08-35	Motor Overheating Fault Selection	0: Disable 1: Deceleration to Stop 2: Coast to Stop 3: Keep Running	0	
08-36	PTC Input Filter Time Constant	0.00 ~ 5.00	2.00	
08-38	Delay Time of Fan Off	0~600	60	
08-39	Delay Time of Motor Overheat Protection	1~300	60	
08-40	Motor2 Acceleration Stall Prevention Level	20~200	HD: 150 ND: 120	
08-41	Motor2 Acceleration Stall Prevention	1~100	50	

Group 08: Protection Parameters				
Code	Parameter Name	Setting Range	Default	Attribute
	Limit			
08-42	PTC Protection Level	0.1~10.0V	0.7	
08-43	PTC Restart Level	0.1~10.0V	0.3	
08-44	PTC Warning Level	0.1~10.0V	0.5	
08-46	Temperature Agree Level	0~254°C	0	
08-47	Temperature Reset Level	0~254°C	0	
08-48	Selection of Fire Mode	0: Disable 1: Enable	0	
08-49	Multi-Function Terminal Status of Fire Mode	0: Reset after Power Off 1: Reset after Power Removed	0	
08-50	Multi-Function Terminal Status of Fire Mode	xxx0b: S6 A Contact xxx1b: S6 B Contact	0000b	
08-51	Motor Speed Setting Source of Fire Mode	0: Fire Mode Speed (08-52) 1: PID Control 2: AI2	0	
08-52	Motor Speed of Fire Mode	0.00~100.00	100.00	
08-53	PID Detection Level of Fire Mode	0~100	0	
08-54	Delay Time of Fire Mode PID Loss	0.0~10.0	0.0	
08-55	PID Feedback Loss Detection Selection of Fire Mode	0: Keep Running 1: Fire Mode Speed(08-52) 2: Max Output Frequency (01-02)	0	
08-56	Detection Level of Fire Mode AI2 Signal	0~100	0	
08-57	Delay Time of Fire Mode AI2 Signal Loss	0.0~10.0	0.0	
08-58	Selection of Fire Mode AI2 Signal Loss	0: Keep Running 1: Fire Mode Speed(08-52) 2: Max Output Frequency (01-02)	0	
08-59	Fire Mode Motor Detection	0: Forward 1: Reverse	0	
08-60	Fire Mode	00000~65534	0	

Group 08: Protection Parameters				
Code	Parameter Name	Setting Range	Default	Attribute
	Password			

***STO function is only designed in EMC filter built-in models.

Group 09: Communication Parameters				
Code	Parameter Name	Setting Range	Default	Attribute
09-00	INV Communication Station Address	1~254	1	*3
09-01	Communication Mode Selection	0: MODBUS 1: BACnet 3: PUMP in Parallel Connection	0	*3
09-02	Baud Rate Setting (bps)	2: 4800 3: 9600 4: 19200 5: 38400	4	*3
09-03	Stop Bit Selection	0: 1 Stop Bit 1: 2 Stop Bit	0	*3
09-04	Parity Selection	0: No Parity 1: Even Bit 2: Odd Bit	0	*3
09-05	Communication Data Bit Selection	0: 8 Bit Data 1: 7 Bit Data	0	*3
09-06	Communication Error Detection Time	0.0~25.5	0.0	*3
09-07	Fault Stop Selection	0: Deceleration to Stop By Deceleration Time 1 1: Coast to Stop 2: Deceleration to Stop By Deceleration Time 2 3: Keep Operating	3	*3
09-08	Comm. Fault Tolerance Count	1~20	1	*3
09-09	Waiting Time	5~65	5	*3
09-10	BACNET Device Instance Number	1~254	1	*3

*3: Parameter group 09 will not be effected by factory setting. (13-08).

Group 10: PID Parameters				
Code	Parameter Name	Setting Range	Default	Attribute
10-00	PID Target Value Source Setting	0: Keypad given	1	
		1: AI1 given		
		2: AI2 given		
		3: Communication given		
10-01	PID Feedback Value Source Setting	0: Keypad given	2	
		1: AI1 given		
		2: AI2 given		
		3: Communication given		
10-02	PID Target Value	0.00~100.00	0.00	*1
10-03	PID Control Mode	xxx0b: PID Disable	0000b	
		xxx1b: PID Enable		
		xx0xb: PID Positive Characteristic		
		xx1xb: PID Negative Characteristic		
		x0xxb: PID Error Value of D Control		
		x1xxb: PID Feedback Value of D Control		
		0xxxb: PID Output		
		1xxxb: PID Output + Frequency Command		
10-04	Feedback Gain	0.01~10.00	1.00	*1
10-05	Proportional Gain (P)	0.00~10.00	1.00	*1
10-06	Integral Time (I)	0.00~100.00	1.00	*1
10-07	Differential Time (D)	0.00~10.00	0.00	*1
10-08	Primary Delay Filter Time	1~250	4	*1
10-09	PID Bias	-100.0~100.0	0	*1
10-11	PID Feedback Loss Detection Selection	0: Disable	0	
		1: Warning		
		2: Fault		
10-12	PID Feedback Loss Det. Lev.	0~100	0	
10-13	PID Feedback Loss Det. Time	0.0~25.5	1.0	
10-14	PID Integral	0.0~100.0	100.0	*1

Group 10: PID Parameters				
Code	Parameter Name	Setting Range	Default	Attribute
	Limit			
10-17	*Start Frequency of PID Sleep	0.00~599.00	0.00	
10-18	Delay Time of PID Sleep	0.0~255.5	0.0	
10-19	*Frequency of PID Waking up	0.00~599.00	0.00	
10-20	Delay Time of PID Waking up	0.0~255.5	0.0	
10-21	Reserved			
10-22	Reserved			
10-23	PID Output Limit	0.00~100.0	100.0	*1
10-24	PID Output Gain	0.0~25.0	1.0	
10-25	PID Reversal Output Selection	0: No Allowing Reversal Output	0	
		1: Allow Reversal Output		
10-26	PID Target Acceleration/Deceleration Time	0.0~25.5	0.0	
10-27	PID Feedback Display Bias	-99.99~99.99	0	
10-29	PID Sleep Selection	0: Disable	1	
		1: Enable		
		2: set by DI		
10-30	Upper Limit of PID Target	0.0 ~ 100.0	100.0	
10-31	Lower Limit of PID Target	0.0 ~ 100.0	0.0	
10-33	Maximum Value of PID Feedback	1 ~ 10000	999	
10-34	PID Decimal Width	0 ~ 4	1	
10-35	PID Unit	0: %	0	*7
		1: FPM		
		2: CFM		
		3: SPI		
		4: GPH		
		5: GPM		
		6: IN		
		7: FT		
		8: /s		
		9: /m		
		10: /h		
		11: °F		
		12: inW		
		13: HP		
		14: m/s		
		15: MPM		
		16: CMM		

Group 10: PID Parameters				
Code	Parameter Name	Setting Range	Default	Attribute
		17: W		
		18: KW		
		19: m		
		20: °C		
		21: RPM		
		22: Bar		
		23: Pa		
24: kPa				
10-39	*Output Frequency Setting of PID Disconnection	00.00~599.00	30.00	
10-40	Selection of PID Sleep Compensation Frequency	0: Disable	0	
		1: Enable		
10-47	Proportional Gain (P) of Fire Mode	0.00~10.00	1.00	*1
10-48	Integral Time (I) of Fire Mode	0.00~100.00	1.00	*1
10-49	Differential Time (D) of Fire Mode	0.00~10.00	0.00	*1

Group 11: Auxiliary Parameters				
Code	Parameter Name	Setting Range	Default	Attribute
11-00	Direction Lock Selection	0: Allow Forward and Reverse Rotation	0	
		1: Only Allow Forward Rotation		
		2: Only Allow Reverse Rotation		
11-01	Carrier frequency	0: Carrier Output Frequency Tuning 1~16: 1~16KHz	*	
11-02	Soft PWM Function Selection	0: Disable	0	
		1: Soft PWM		
11-03	Automatic carrier lowering selection	0: Disable	0	
		1: Enable		
11-04	S-curve Time Setting at the Start of Acceleration	0.00~2.50	0.20	
11-05	S-curve Time Setting at the	0.00~2.50	0.20	

Group 11: Auxiliary Parameters				
Code	Parameter Name	Setting Range	Default	Attribute
	Stop of Acceleration			
11-06	S-curve Time Setting at the Start of Deceleration	0.00~2.50	0.20	
11-07	S-curve Time Setting at the Stop of Deceleration	0.00~2.50	0.20	
11-08	Jump Frequency 1	0.0~599.0	0.0	
11-09	Jump Frequency 2	0.0~599.0	0.0	
11-10	Jump Frequency 3	0.0~599.0	0.0	
11-11	Jump Frequency Width	0.00 ~ 25.5	1.0	
11-12	Manual Energy Saving Gain (V/F)	0~100	80	
11-14	OV Prevention Selection	230V: 200V~400V 400V: 400V~800V	370 740	
11-17	Acceleration/Deceleration Gain	0.1~10.0	1	
11-18	Manual Energy Saving Frequency	0.0~599.0	0.0	
11-28	Frequency Gain of Over Voltage Prevention 2	1~200	100	
11-33	DC Voltage Filter Rise Amount	0.1~10.0	0.1	
11-34	DC Voltage Filter Fall Amount	0.1~10.0	5.0	*1
11-35	DC Voltage Filter Deadband Level	0.0~99.0	10.0	*1
11-36	Frequency gain of OV Prevention	0.000~1.000	0.050	*1
11-37	Frequency limit of OV Prevention	*0.00~599.00	5.00	*1
11-38	Deceleration start voltage of OV prevention	200V: 200~400V	300	
		400V: 400~800V	700	
11-39	Deceleration end voltage of OV Prevention	200V: 300~400V	350	
		400V: 600~800V	750	

Group 11: Auxiliary Parameters				
Code	Parameter Name	Setting Range	Default	Attribute
11-40	OV Prevention Selection	0~3	0	
11-47	KEB Deceleration Time	0.0~25.5	0.0	*1
11-48	KEB Detection Level	230V: 190~210	200V	
		400V: 380~420	400V	
11-55	STOP Key Selection	0: Stop Key is Disabled when the Operation Command is not Provided by Operator.	1	
		1: Stop Key is Enabled when the Operation Command is not Provided by Operator.		
11-59	Gain of Preventing Oscillation	0.00~2.50	*	
11-60	Upper Limit of Preventing Oscillation	0~100	*	
11-61	Time Parameter of Preventing Oscillation 1	0~100	0	
11-62	Selection of Preventing Oscillation	0: Mode 1	1	
		1: Mode 2		
		2: Mode 3		
11-63	Strong Magnetic Selection	0: Disable	1	
		1: Enable		
11-69	Gain of Preventing Oscillation 2	0.00~200.00	5.00	
11-70	Upper Limit of Preventing Oscillation 2	0.01~100.00	5.00	
11-71	Time of Preventing Oscillation 2	0~30000	100	
11-72	Switch Frequency 1 of Preventing Oscillation 2	0.01~300.00	30.00	
11-73	Switch Frequency 2 of Preventing Oscillation 2	0.01~300.00	50.00	

* If the maximum output frequency of motor is over 300HZ, the frequency resolution is changed to 0.1Hz.

Note: The parameter of 11-01 can be changed during run operation, the range is 1~16KHz.

Group 12: Monitoring Parameters				
Code	Parameter Name	Setting Range	Default	Attribute
12-00	Display Screen Selection (LED)	00000~88888	00000	*1 *6
		From the leftmost bit, it displays the screen when press DSP key in order. 0: no display 1: Output Current 2: Output Voltage 3: DC Bus Voltage 4: Heatsink Temperature* 5: PID Feedback 6: AI1 Value 7: AI2 Value 8: Counter Value		
12-01	PID Feedback Display Mode (LED)	0: Display the Feedback Value by Integer (xxx)	0	*6
		1: Display the Feedback Value by the Value with One Decimal Place (xx.x)		
		2: Display the Feedback Value by the Value with Two Decimal Places (x.xx)		
12-02	PID Feedback Display Unit Setting (LED)	0: xxxxx (no unit)	0	*6
		1: xxxPb (pressure)		
		2: xxxFL (flow)		
12-03	Line Speed Display (LED)	0~60000	1500/1800	*1 *6
12-04	Modes of Line Speed Display (LED)	0: Display Inverter Output Frequency	0	*1 *6
		1: Display Line Speed with integer (xxxxx)		
		2: Display Line Speed with the First Decimal Place (xxxx.x)		
		3: Display Line Speed with the Second Decimal Place (xxx.xx)		

Group 12: Monitoring Parameters				
Code	Parameter Name	Setting Range	Default	Attribute
		4: Display Line Speed with the Third Decimal Place (xx.xxx)		
12-05	Status Display of Digital Input & Output Terminal (LED / LCD)	<p>LCD display is shown as below</p> <p>LED display is shown as below no input</p> <p>correspondences to input and output</p>	-	*4
12-11	Output Current of Current Fault	Display the output current of current fault	-	*4
12-12	Output Voltage of Current Fault	Display the output voltage of current fault	-	*4
12-13	Output Frequency of Current Fault	Display the output frequency of current fault	-	*4
12-14	DC Voltage of Current Fault	Display the DC voltage of current fault	-	*4
12-15	Frequency Command of Current Fault	Display the frequency command of current fault	-	*4
12-16	Frequency Command	If LED enters this parameter, it only allows monitoring frequency command.	-	*4
12-17	Output Frequency	Display the current output frequency	-	*4
12-18	Output Current	Display the current output current	-	*4
12-19	Output Voltage	Display the current output voltage	-	*4

Group 12: Monitoring Parameters				
Code	Parameter Name	Setting Range	Default	Attribute
12-20	DC Voltage (Vdc)	Display the current DC voltage	-	*4
12-21	Output Power (kw)	Display the current output power	-	*4
12-28	Motor Torque Current (Iq)	Display the current q-axis current		*4
12-29	Motor Excitation Current (Id)	Display the current d-axis current		*4
12-36	PID Input	Display input error of the PID controller (PID target value - PID feedback) (100% corresponds to the maximum frequency set by 01-02 or 01-16)		*4
12-37	PID Output	Display output of the PID controller (100% corresponds to the maximum frequency set by 01-02 or 01-16)		*4
12-38	PID Setting	Display the target value of the PID controller (100% corresponds to the maximum frequency set by 01-02 or 01-16)		*4
12-39	PID Feedback	Display the feedback value of the PID controller (100% corresponds to the maximum frequency set by 01-02 or 01-16)		*4
12-41	Heatsink Temperature*	Display the heatsink temperature of IGBT temperature**		*4

Group 13: Maintenance Parameters				
Code	Parameter Name	Setting Range	Default	Attribute
13-27	Previous Seven Fault History	Exhibit previous seven fault history	-	
13-28	Previous Eight Fault History	Exhibit previous eight fault history	-	
13-29	Previous Nine Fault History	Exhibit previous nine fault history	-	
13-30	Previous Ten Fault History	Exhibit previous ten fault history	-	
13-31	Previous Eleven Fault History	Exhibit previous eleven fault history	-	
13-32	Previous Twelve Fault History	Exhibit previous twelve fault history	-	
13-33	Previous Thirteen Fault History	Exhibit previous thirteen fault history	-	
13-34	Previous Fourteen Fault History	Exhibit previous fourteen fault history	-	
13-35	Previous Fifteen Fault History	Exhibit previous fifteen fault history	-	
13-36	Previous Sixteen Fault History	Exhibit previous sixteen fault history	-	
13-37	Previous Seventeen Fault History	Exhibit previous seventeen fault history	-	
13-38	Previous Eighteen Fault History	Exhibit previous eighteen fault history	-	
13-39	Previous Nineteen Fault History	Exhibit previous nineteen fault history	-	
13-40	Previous Twenty Fault History	Exhibit previous twenty fault history	-	
13-41	Previous Twenty one	Exhibit previous twenty	-	

Group 13: Maintenance Parameters				
Code	Parameter Name	Setting Range	Default	Attribute
	Fault History	one fault history		
13-42	Previous Twenty Two Fault History	Exhibit previous twenty two fault history	-	
13-43	Previous Twenty Three Fault History	Exhibit previous twenty three fault history	-	
13-44	Previous Twenty Four Fault History	Exhibit previous twenty four fault history	-	
13-45	Previous Twenty Five Fault History	Exhibit previous twenty five fault history	-	
13-46	Previous Twenty Six Fault History	Exhibit previous twenty six fault history	-	
13-47	Previous Twenty Seven Fault History	Exhibit previous twenty seven fault history	-	
13-48	Previous Twenty Eight Fault History	Exhibit previous twenty eight fault history	-	
13-49	Previous Twenty Nine Fault History	Exhibit previous twenty nine fault history	-	
13-50	Previous Thirty Fault History	Exhibit previous thirty fault history	-	
13-51	Operation Time Clearance Function	0 : Do not clear operation time 1 : Clear operation time	0	*1

Group 14: PLC Setting Parameters				
Code	Parameter Name	Setting Range	Default	Attribute
14-00	T1 Set Value 1	0~9999	0	
14-01	T1 Set Value 2 (Mode 7)	0~9999	0	
14-02	T2 Set Value 1	0~9999	0	
14-03	T2 Set Value 2 (Mode 7)	0~9999	0	
14-04	T3 Set Value 1	0~9999	0	
14-05	T3 Set Value 2 (Mode 7)	0~9999	0	

Group 14: PLC Setting Parameters				
Code	Parameter Name	Setting Range	Default	Attribute
14-06	T4 Set Value 1	0~9999	0	
14-07	T4 Set Value 2 (Mode 7)	0~9999	0	
14-08	T5 Set Value 1	0~9999	0	
14-09	T5 Set Value 2 (Mode 7)	0~9999	0	
14-10	T6 Set Value 1	0~9999	0	
14-11	T6 Set Value 2 (Mode 7)	0~9999	0	
14-12	T7 Set Value 1	0~9999	0	
14-13	T7 Set Value 2 (Mode 7)	0~9999	0	
14-14	T8 Set Value 1	0~9999	0	
14-15	T8 Set Value 2 (Mode 7)	0~9999	0	
14-16	C1 Set Value	0~65534	0	
14-17	C2 Set Value	0~65534	0	
14-18	C3 Set Value	0~65534	0	
14-19	C4 Set Value	0~65534	0	
14-20	C5 Set Value	0~65534	0	
14-21	C6 Set Value	0~65534	0	
14-22	C7 Set Value	0~65534	0	
14-23	C8 Set Value	0~65534	0	
14-24	AS1 Set Value 1	0~65534	0	
14-25	AS1 Set Value 2	0~65534	0	
14-26	AS1 Set Value 3	0~65534	0	
14-27	AS2 Set Value 1	0~65534	0	
14-28	AS2 Set Value 2	0~65534	0	
14-29	AS2 Set Value 3	0~65534	0	
14-30	AS3 Set Value 1	0~65534	0	
14-31	AS3 Set Value 2	0~65534	0	
14-32	AS3 Set Value 3	0~65534	0	
14-33	AS4 Set Value 1	0~65534	0	
14-34	AS4 Set Value 2	0~65534	0	
14-35	AS4 Set Value 3	0~65534	0	
14-36	MD1 Set Value 1	0~65534	1	
14-37	MD1 Set Value 2	0~65534	1	
14-38	MD1 Set Value 3	1~65534	1	
14-39	MD2 Set Value 1	0~65534	1	

Group 14: PLC Setting Parameters				
Code	Parameter Name	Setting Range	Default	Attribute
14-40	MD2 Set Value 2	0~65534	1	
14-41	MD2 Set Value 3	1~65534	1	
14-42	MD3 Set Value 1	0~65534	1	
14-43	MD3 Set Value 2	0~65534	1	
14-44	MD3 Set Value 3	1~65534	1	
14-45	MD4 Set Value 1	0~65534	1	
14-46	MD4 Set Value 2	0~65534	1	
14-47	MD4 Set Value 3	1~65534	1	

Group 15: PLC Monitoring Parameters				
Code	Parameter Name	Setting Range	Default	Attribute
15-00	T1 Current Value 1	0~9999	0	*4
15-01	T1 Current Value 2 (Mode7)	0~9999	0	*4
15-02	T2 Current Value 1	0~9999	0	*4
15-03	T2 Current Value 2 (Mode7)	0~9999	0	*4
15-04	T3 Current Value 1	0~9999	0	*4
15-05	T3 Current Value 2 (Mode7)	0~9999	0	*4
15-06	T4 Current Value 1	0~9999	0	*4
15-07	T4 Current Value 2 (Mode7)	0~9999	0	*4
15-08	T5 Current Value 1	0~9999	0	*4
15-09	T5 Current Value 2 (Mode7)	0~9999	0	*4
15-10	T6 Current Value 1	0~9999	0	*4
15-11	T6 Current Value 2 (Mode7)	0~9999	0	*4
15-12	T7 Current Value 1	0~9999	0	*4
15-13	T7 Current Value 2 (Mode7)	0~9999	0	*4
15-14	T8 Current Value 1	0~9999	0	*4

Group 15: PLC Monitoring Parameters				
Code	Parameter Name	Setting Range	Default	Attribute
15-15	T8 Current Value 2 (Mode7)	0~9999	0	*4
15-16	C1 Current Value	0~65534	0	*4
15-17	C2 Current Value	0~65534	0	*4
15-18	C3 Current Value	0~65534	0	*4
15-19	C4 Current Value	0~65534	0	*4
15-20	C5 Current Value	0~65534	0	*4
15-21	C6 Current Value	0~65534	0	*4
15-22	C7 Current Value	0~65534	0	*4
15-23	C8 Current Value	0~65534	0	*4
15-24	AS1 Current Value	0~65534	0	*4
15-25	AS2 Current Value	0~65534	0	*4
15-26	AS3 Current Value	0~65534	0	*4
15-27	AS4 Current Value	0~65534	0	*4
15-28	MD1 Current Value	0~65534	0	*4
15-29	MD2 Current Value	0~65534	0	*4
15-30	MD3 Current Value	0~65534	0	*4
15-31	MD4 Current Value	0~65534	0	*4
15-32	TD Current Value	0~65534	0	*4

Group 16: LCD Function Parameters				
Code	Parameter Name	Setting Range	Default	Attribute
16-00	Main Screen Monitoring	5~83 when using LCD to operate, the monitored item displays in the first line. (default is frequency command)	16	*1*7
16-01	Sub-Screen Monitoring 1	5~83 when using LCD to operate, the monitored item displays	17	*1*7

Group 16: LCD Function Parameters				
Code	Parameter Name	Setting Range	Default	Attribute
		in the second line. (default is output frequency)		
16-02	Sub-Screen Monitoring 2	5~83 when using LCD to operate, the monitored item displays in the third line. (default is output current))	18	*1*7
16-03	Display Unit	0~39999 Determine the display way and unit of frequency command 0: Frequency display unit is 0.01Hz 1: Frequency display unit is 0.01% 2: Frequency display unit is RPM. 3~39: Reserved 40~9999: Users specify the format, Input 00XXXX represents the display of XXXX at 100%. 10001~19999: Users specify the format; Input 1XXXX represents the display of XXX.X at 100%. 20001~29999: Users specify the format, Input 2XXXX represents the display of XX.XX at 100%. 30001~39999: Users specify the format, Input 3XXXX represents the display of X.XXX at	0	*7

Group 16: LCD Function Parameters				
Code	Parameter Name	Setting Range	Default	Attribute
		100%.		
16-04	Engineering Unit	0: without using engineering unit	0	*7
		1: FPM		
		2: CFM		
		3: PSI		
		4: GPH		
		5: GPM		
		6: IN		
		7: FT		
		8: /s		
		9: /m		
		10: /h		
		11: °F		
		12: inW		
		13: HP		
		14: m/s		
		15: MPM		
		16: CMM		
		17: W		
		18: kW		
		19: m		
		20: °C		
		21: RPM		
		22: Bar		
		23: Pa		
24: kPa				
16-05	LCD Backlight	0~7	5	*1*7
16-07	Copy Function Selection	0: Do not copy parameters	0	*7
		1: Read inverter parameters and save them to the operator.		
		2: Write the operator parameters to inverter.		
		3: Compare parameters of inverter and operator.		
16-08	Selection of Allowing Reading	0: Do not allow to read inverter parameters or save them to the operator.	0	*7
		1: Allow to read inverter parameters and save to the operator.		
16-09	Selection of Operator Removed (LCD)	0: Keep operating when LCD operator is removed.	0	*1*7

Group 16: LCD Function Parameters				
Code	Parameter Name	Setting Range	Default	Attribute
		1: Display fault when LCD operator is removed		

Group 17: Automatic Tuning Parameters				
Code	Parameter Name	Setting Range	Default	Attribute
17-00	Mode Selection of Automatic Tuning*	0: Rotation Auto-tuning	V/F : 2 SLV : 6	
		1: Static Auto-tuning		
		2: Stator Resistance Measurement		
		3: Reserved		
		4: Loop Tuning		
		5: Rotation Auto-tuning Combination (item: 4+2+0)		
		6: Static Auto-tuning Combination (item: 4+2+1)		
17-01	Motor Rated Output Power	0.00~600.00	KVA	
17-02	Motor Rated Current	0.1~1200.0	KVA	
17-03	Motor Rated Voltage	200V: 50.0~240.0	220	
		400V: 100.0~480.0	440	
17-04	Motor Rated Frequency	4.8~599.0	60.0	
17-05	Motor Rotated Speed	0~24000	KVA	
17-06	Pole Number of Motor	2~16(Even)	4	
17-08	Motor no-load Voltage	200V: 50~240	KVA	
		400V:100~480		
17-09	Motor Excitation Current	0.01~600.00	KVA	
17-10	Automatic Tuning Start	0: Disable	0	
		1: Enable		
17-11	Error History of Automatic Tuning	0: No error	0	*4
		1: Motor data error		
		2: Stator resistance tuning error		
		3: Leakage induction tuning error		
		4: Rotor resistance tuning error		
		5: Mutual		

Group 17: Automatic Tuning Parameters

Code	Parameter Name	Setting Range	Default	Attribute
		induction tuning error		
		6: DT Error		
		7: Encoder error		
		8: Motor's acceleration error		
		9: Warning		
17-12	Proportion of Motor Leakage Inductance	0.1~15.0	KVA	
17-13	Motor Slip Frequency	0.10~20.00	KVA	
17-14	Selection of Rotation Auto-tuning	0: VF Rotation Auto-tuning 1: Vector Rotation Auto-tuning	0	

KVA: The default value of this parameter will be changed by different capacities of inverter. It is suggested that HD/ ND mode (00-27) be selected first before motor performs auto-tuning.

Note: The value of mode selection of automatic tuning is 6 (Static Auto-tuning Combination). When do auto-tuning with no-load motor, it is suggested to select 17-00=5 (Rotation Auto-tuning Combination)

Group 18: Slip Compensation Parameters

Code	Parameter Name	Setting Range	Default	Attribute
18-00	Slip Compensation Gain at Low Speed.	0.00~2.50	VF:0.00	*1
			SLV:***	
18-01	Slip Compensation Gain at High Speed.	-1.00~1.00	0.0	*1
18-02	Slip Compensation Limit	0~250	200	
18-03	Slip Compensation Filter Time	0.0~10.0	1.0	
18-04	Regenerative Slip Compensation Selection	0 : Disable 1 : Enable	0	
18-05	FOC Delay Time	1~1000	100	
18-06	FOC Gain	0.00~2.00	0.1	

***: Refer to the following attachment 1

Group 20: Speed Control Parameters

Code	Parameter Name	Setting Range	Default	Attribute
20-00	ASR Gain 1	0.00~250.00	-	*1
20-01	ASR Integral Time 1	0.001~10.000	-	*1
20-02	ASR Gain 2	0.00~250.00	-	*1
20-03	ASR Integral Time 2	0.001~10.000	-	*1
20-04	ASR Integral Time Limit	0~300	200	
20-07	Selection of Acceleration and Deceleration of P/PI	0: PI speed control will be enabled only in constant speed. For the speed acceleration and deceleration, only use P control. 1: Speed control is enabled either in acceleration or deceleration.	0	
20-08	ASR Delay Time	0.000~0.500	0.004	
20-09	Speed Observer Proportional (P) Gain1	0.00~2.55	0.61	*1
20-10	Speed Observer Integral(I) Time 1	0.01~10.00	0.05	*1
20-11	Speed Observer Proportional (P) Gain2	0.00~2.55	0.61	*1
20-12	Speed Observer Integral(I) Time 2	0.01~10.00	0.06	*1
20-13	Low-pass Filter Time Constant of Speed Feedback 1	1~1000	4	
20-14	Low-pass Filter Time Constant of Speed Feedback 2	1~1000	30	
20-15	ASR Gain Change Frequency 1	0.0~599.0	4.0	
20-16	ASR Gain Change Frequency 2	0.0~599.0	8.0	

Group 20: Speed Control Parameters				
Code	Parameter Name	Setting Range	Default	Attribute
20-17	Torque Compensation Gain at Low Speed	0.00~2.50	1.00	*1
20-18	Torque Compensation Gain at High Speed	-10~10	0	*1
20-33	Detection Level at Constant Speed	0.1~5.0	1.0	*1
20-34	Compensation Gain of Derating	0~25600	0	*1
20-35	Compensation Time of Derating	0~30000	100	*1

Group 21: Torque And Position Control Parameters				
Code	Parameter Name	Setting Range	Default	Attribute
21-05	Positive Torque Limit	0~300	150	*1
21-06	Negative Torque Limit	0~300	150	*1
21-07	Forward Regenerative Torque Limit	0~300	150	*1
21-08	Reversal Regenerative Torque Limit	0~300	150	*1

Group 22: PM Motor Parameters				
Code	Parameter Name	Setting Range	Default	Attribute
22-00	PM Motor Rated Power	0.00~600.00	KVA	
22-02	PM Motor Rated Current	25%~200% inverter rated current	KVA	
22-03	PM Motor's Pole Number	2~96	8	
22-04	PM Motor's Rotation Speed	6~60000	1500	
22-05	PM Motor's Maximum Rotation Speed	6~60000	1500	
22-06	PM Motor Rated Frequency	4.8~599.0	75.0	
22-07	PM Motor Type Selection	0: SPM 1: IPM	0	

Group 21: Torque And Position Control Parameters				
Code	Parameter Name	Setting Range	Default	Attribute
22-10	PM SLV Start Current	20% ~ 200% Motor Rated Current	50	
22-11	I/F Mode Start Frequency Switching Point	1.0 ~ 20.0	10.0	
22-14	Armature Resistance of PM Motor	0.001 ~ 30.000	1.000	
22-15	D-axis Inductance of PM Motor	0.01 ~ 300.00	10.00	
22-16	Q-axis Inductance of PM Motor	0.01 ~ 300.00	10.00	
22-18	Flux-Weakening Limit	0~120	90	
22-21	PM Motor Tuning	0: PM Motor Tuning is not Active. 1: Parameter Auto-tune Mode 1 2: Parameter Auto-tune Mode 2 3: Rotation Auto-tuning	0	
22-22	Fault History of PM Motor Tuning	0: None 1: Static Magnetic Alignment Fault 2~4 : Reserved 5: Loop Adjustment is Time Out 6: Reserved 7: Other Errors of Motor Tuning 8:Reserved 9:Current Abnormity Occurs when Loop Adjustment 10: Reserved 11: Stator Resistance Measurement Timeout	0	*4
22-23	PMSLV acceleration time	0.1~10.0	1.0	

Group 21: Torque And Position Control Parameters				
Code	Parameter Name	Setting Range	Default	Attribute
22-25	Detection Mode Selection of Initial Magnetic Pole	0: Upon the angle before stopping 1: Detection Mode 1 2: Detection Mode 2 3: Detection Mode 3	2	
22-26	High speed control ratio enable (For PMSLV)	0: Low Speed Open Loop Control 1: Low Speed High Frequency Estimate Control 2: Full Closed Loop Control	0	
22-27	Voltage Command of Mode 2	5~120 (22-25=2 or 22-26=1 is enabled)	50	
22-28	Divider Ratio of Mode 2	0~8 (22-25=2 or 22-26=1 is enabled)	2	
22-29	Flux-weakening Voltage Command Restriction	80~110 (related to parameter 22-18)	100	
22-32	MTPA Selection	0: Disabled 1: Mode 1 2: Mode 2 3: Mode 3	0	
22-33	MTPA Gain	0~400%	200	
22-34	IPM Estimator Gain	1~300.0	180	
22-38	Open and closed loop switching point frequency width (%)	1.0~40.0	5.0	
22-39	Preliminary DC injection time	0~20.00	0.10	
22-40	High frequency angle finding time	0.01~1.00	0.01	
22-41	PM stop method	0: Decelerate or stop below 22-11 and brake directly 1: Decelerate or stop below	0	

Group 21: Torque And Position Control Parameters				
Code	Parameter Name	Setting Range	Default	Attribute
		22-11 and open loop stop		
22-42	Fully closed loop control gain Ka	64~8192	100	
22-43	Fully closed loop control gain Kb	64~8192	2000	
22-44	Fully closed loop control gain speed low pass filter	1~256	4	
22-45	Fully closed loop control magnetic flux	0.01~10.00	0.70	

Group 23 PUMP & HVAC				
Code	Parameter Name	Setting Range	Default	Attribute
23-00	Function Selection	0: Disable 1: PUMP 2: HVAC 3: Compressor	0	
23-01	Setting of Single & Multiple Pumps and Master & Slave Machines	0: Single Pump 1: Master 2: Slave 1 3: Slave 2 4: Slave 3	0	
23-02	Operation Pressure Setting	0.10 ~ 650.00	2.00	
23-03	Maximum Pressure Setting of Pressure Transmitter	0.10 ~ 650.00	10.00	
23-04	Pump Pressure Command Source	0 : Set by 23-02 1 : Set by AI	0	
23-05	Display Mode Selection	0: Display of Target and Pressure Feedback 1: Target Pressure Only 2: Feedback Pressure Only	0	
23-06	Proportion Gain(P)	0.00~10.00	3.00	

Group 23 PUMP & HVAC				
Code	Parameter Name	Setting Range	Default	Attribute
23-07	Integral Time(I)	0.0~100.0	0.5	
23-08	Differential Time(D)	0.00~10.00	0.00	
23-09	Tolerance Range of Constant Pressure	0.01 ~ 650.00	0.5	
23-10	Sleep Frequency of Constant Pressure	0.00 ~ 599.00	30.00	
23-11	Sleep Time of Constant Pressure	0.0 ~ 255.5	0.0	
23-12	Maximum Pressure Limit	0.00 ~ 650.00	5	
23-13	Warning Time of High Pressure	0.0 ~ 600.0	10.0	
23-14	Stop Time of High Pressure	0.0 ~ 600.0	20.0	
23-15	Minimum Pressure Limit	23-20=0 : 0.00 ~ 650.00 23-20=1 : 0~100	5	
23-16	Warning Time of Low Pressure	0.0 ~ 600.0	0.0	
23-17	Fault Stop Time of Low Pressure	0.0 ~ 600.0	0.0	
23-18	Time of Loss Pressure Detection	0.0 ~ 600.0	0.0	
23-19	Proportion of Loss Pressure Detection	0 ~ 100	0	
23-22	Slave Trip Frequency	0.00 ~ 599.00	45.00	
23-23	Direction of Water Pressure Detection	0: Upward Detection 1: Downward Detection	1	
23-24	Range of Water Pressure Detection	0.00 ~ 65.00	0.1	
23-25	Period of Water Pressure Detection	0.0 ~ 200.0	30.0	
23-26	Acceleration Time of Water Pressure Detection	0.1 ~ 6000.0	KVA	
23-27	Deceleration Time of Water	0.1 ~ 6000.0	KVA	



Group 23 PUMP & HVAC				
Code	Parameter Name	Setting Range	Default	Attribute
	Pressure Detection			
23-28	Forced Run Command	0.00 ~ 599.00	0.00	
23-29	Switching Time of Water Pressure Detection	0 ~ 240	3	
23-30	Detection Time of Multiple Pumps in Parallel Running Start	0.0 ~ 30.0	5.0	
23-31	Synchronous Selection of Multiple Pumps in Parallel	0: Disable 1: Pressure Setting Run/Stop 2: Pressure Setting 3: Run/Stop	1	
23-34	Tolerance Range of Constant Pressure 2	0.01 ~ 650.00	0.5	
23-35	Selection of Multiple Pumps Shift Operation	0: No Function 1: Timer Alternately Selection 2: Sleep Stop Alternately Selection 3: Timer and Sleep Stop Alternately Selection 4: Multiple Pumps Test Mode	1	
23-37	Leakage Detection Time	0.0~100.0	0.0	
23-38	Pressure Variation of Leakage Detection Restart	0.01 ~ 65.00	0.1	
23-39	Pressure Tolerance Range of Leakage Detection Restart	0.01 ~ 650.00	0.5	
23-71	Maximum Pressure Setting	0.10~650.00	10.00	
23-72	Switching Time of Alternation in Parallel	0: Hour 1: Minute	0	









Group 23 PUMP & HVAC				
Code	Parameter Name	Setting Range	Default	Attribute
23-73	Slave Wake-Up Selection	0: Disable 1: Enable	0	
23-74	High Pressure Setting	0: Disable 1: High Pressure Warning 2: High Pressure Warning or Error	2	
23-75	Low Pressure Setting	0: Disable 1: Low Pressure Warning 2: Low Pressure Warning or Error	0	
23-78	Selection of Loss Pressure Detection	0: Disable 1: Loss Pressure Warning 2: Low Pressure Error	0	

Chapter 4 Troubleshooting and Fault Diagnostics

4.1 Fault Detection Function

Table 4.1.1 Fault information and possible solutions

LED display	Possible solutions
OC over current	<ul style="list-style-type: none"> Extend acceleration / deceleration time. Check the motor wiring. Disconnect motor and try running inverter.
	
OCA over current	<ul style="list-style-type: none"> Set the longer acceleration time Change to bigger capacity of inverter Examine motor Check the wire Replace IGBT module
	
OCC over current	<ul style="list-style-type: none"> Set the longer acceleration time Change to bigger capacity of inverter Examine motor Check the wire Replace IGBT module
	

LED display	Possible solutions
OCd over current	<ul style="list-style-type: none"> Set the longer acceleration time
	
GF Ground fault	<ul style="list-style-type: none"> Replace motor. Check the motor wiring. Disconnect motor and try running inverter. Check resistance between cables and ground. Reduce carrier frequency.
	
OV Over voltage	<ul style="list-style-type: none"> Increase deceleration time Reduce input voltage to comply with the input voltage requirements or install an AC line reactor to lower the input voltage. Remove the power factor correction capacitor. Use dynamic braking unit. Replace braking transistor or resistor. Adjust speed search parameters.
	
LV Low Voltage	<ul style="list-style-type: none"> Check the input voltage. Check input wiring. Increase acceleration time. Check power source Replace pre-charge contactor Replace control board or complete inverter.
	
IPL input phase loss	<ul style="list-style-type: none"> Check input wiring / faster screws. Check power supply.
	
OPL output phase loss	<ul style="list-style-type: none"> Check output wiring / faster screws. Check motor & inverter rating.
	
OH1 Heatsink overheat	<ul style="list-style-type: none"> Install fan or AC to cool surroundings. Replace cooling fan. Reduce carrier frequency. Reduce load / Measure output current
	
OH4 Motor overheat	<ul style="list-style-type: none"> Check the surrounding temperature of motor. Check the MT and GND terminal wiring be correct
	
OL1 Motor overload	<ul style="list-style-type: none"> Check V/f curve. Check motor rated current Check and reduce motor load, check and operation duty cycle.
	
OL2 Inverter overload	<ul style="list-style-type: none"> Check V/f curve. Replace inverter with larger

LED display	Possible solutions
OL2	rating. • Check and reduce motor load, check and operation duty cycle.
OT Over torque detection	• Check over torque detection parameters (08-15 / 08-16). • Check and reduce motor load, check and operation duty cycle.
OL	
CE communication error	• Check connection • Check host computer / software.
CE	
FB PID feedback loss	• Check feedback wiring • Replace feedback sensor.
Fb	
PO Voltage Off	• Check SF1 and SG connection
PO	
STO 1 Safety 1 Error	• Check SF1 and SG connection.
STO 1	
PO2 Voltage Off	• Check SF2 and SG connection
PO2	
STO2 Safety 2 Error	• Check SF2 and SG connection.
STO2	
PO3 Voltage Off	• Replace the power board • Contact with TECO
PO3	
STO3 Safety 3 Error	• Replace the power board • Contact with TECO.
STO3	
EF0 External fault 0	• Reset Modbus communication 0x2501 bit 2= "1"
EF0	
EF1 External Fault(S1)	
EF1	
EF2 External Fault (S2)	• Multi-function input function set incorrectly. • Check wiring
EF2	
EF3 External Fault (S3)	











LED display	Possible solutions
EF3	
EF4 External Fault (S4)	
EF4	
EF5 External Fault (S5)	
EF5	
EF6 External Fault (S6)	
EF6	
CF07 Motor control fault	• Perform rotational or stationary auto-tune • Increase minimum output frequency (01-08)
CF07	
CF08 Motor control fault	• Increase the value of 22-10 and 22-23 properly. • Re auto-tune (22-21) • Check if the load is too heavy to raise torque output limit.
CF08	
CF00 Operator Communication Error	• Disconnect the operator and then reconnect. • Replace the control board
CF00	
CF01 Operator Communication Error 2	• Disconnect the operator and then reconnect. • Replace the control board
CF01	
OPR Disconnection	• Check the keypad operator connection
OPr	
FBLSS PID Feedback Signal Loss	• Check if the proportion of loss pressure (23-19) is set correctly • Make sure the feedback sensor is installed correctly and PID feedback signal operates normally.
FBLSS	
SC Short circuit	• Check the motor wiring. • Disconnect motor and try running inverter.
SC	
run Motor1/Motor2 Switch	Improve the control sequence, motor can be switched in stop.
run	











LED display	Possible solutions
LPBFT Low Pressure Fault	<ul style="list-style-type: none"> • Check feedback signal is correct and with connection. • Check if feedback value of pressure is lower than limit of minimum pressure (23-15)
OPBFT High Pressure Fault	<ul style="list-style-type: none"> • Check feedback signal is correct and with connection. • Check if feedback value of pressure is lower than limit of minimum pressure (23-12)
PF Protection Error	<ul style="list-style-type: none"> • Remove the digital input or communication run command.
TOL External Overload	<ul style="list-style-type: none"> • Check the reason of external fault. • Reset the digital input terminal of external overload.
FB(flash) PID Feedback Loss	<ul style="list-style-type: none"> • Check feedback wiring. • Replace feedback sensor









Table 4.1.2 warning / self-diagnosis and corrective actions

LED display	Possible solutions
OV (flash) Over voltage	<ul style="list-style-type: none"> • Increase deceleration time • Reduce input voltage to comply with the input voltage requirements or install an AC line reactor to lower the input voltage. • Adjust speed search parameters.
UV (flash) under voltage	<ul style="list-style-type: none"> • Check the input voltage. • Check input wiring. • Replace control board or complete inverter.
OH1 Heatsink overheat	<ul style="list-style-type: none"> • Install fan or AC to cool surroundings. • Replace cooling fan. • Reduce carrier frequency. • Reduce load / Measure output current
OH3 (flash) Motor over Heating warning	<ul style="list-style-type: none"> • Multi-function input function set incorrectly. • Check wiring

LED display	Possible solutions
OT (flash) Over torque detection	<ul style="list-style-type: none"> • Check over torque detection parameters (08-15 / 08-16). • Check and reduce motor load, check and operation duty cycle.
OL1 Motor overload	<ul style="list-style-type: none"> • Check V/f curve. • Check motor rated current • Check and reduce motor load, check and operation duty cycle.
OL2 Inverter overload	<ul style="list-style-type: none"> • Check V/f curve. • Replace inverter with larger rating. • Check and reduce motor load, check and operation duty cycle.
CE Comm. Error	<ul style="list-style-type: none"> • Check connection • Check host computer / software.
Retry (flash)	<ul style="list-style-type: none"> • Warning disappears after automatic reset.
External Emergency Stop	<ul style="list-style-type: none"> • Turn off run command, and remove external emergency stop command.
bb1 (flash) External baseblock	<ul style="list-style-type: none"> • Multi-function input function is set incorrectly. • Check wiring
bb2 (flash) External baseblock	
bb3 (flash) External baseblock	
bb4 (flash) External baseblock	
bb5 (flash)	

LED display	Possible solutions
External baseblock	
	
bb6 (flash) External baseblock	
	
EF9 (flash) Error of forward/reversal rotation	<ul style="list-style-type: none"> • Check run command wiring
	
SE01 Rang setting error	<ul style="list-style-type: none"> • Check parameter setting.
	
SE02 Digital input terminal error	Check multi-function input setting.
	
SE03 V/f curve error	Check V/F parameters
	
SE05 PID selection error	<ul style="list-style-type: none"> • Check 10-00 and 10-01 • Check 10-33,10-34, 23-05.
	
HPErr Model selection error	Check inverter capacity setting 13-00.
	
Over current protection level B	Check load and duty cycle operation.
	
EF1 (flash) External fault (S1)	<ul style="list-style-type: none"> • Multi-function input function set incorrectly. • Check wiring • Multi-function input function set incorrectly. • Check wiring
	

LED display	Possible solutions
EF2 (flash) External fault (S2)	
	
EF3 (flash) External fault (S3)	
	
EF4 (flash) External fault (S4)	
	
EF5 (flash) External fault (S5)	
	
EF6 (flash) External fault (S6)	
	
PI setting error	Check pulse input selection (03-30) and PID source (10-00 and 10-01).
	
FB (flash) PID feedback breaking	<ul style="list-style-type: none"> • Check feedback wiring • Replace feedback sensor.
	
FirE Fire mode enabled	<ul style="list-style-type: none"> • Check the environment and confirm the fire status. If no fire, turn off the power and power on again.
	
PArEr Parameter setting error	<ul style="list-style-type: none"> • Please refer to the manual for correct setting
	
STP1 Direct start warning	<ul style="list-style-type: none"> • Remove the run command from the terminal first, and enabled later.
	

LED display	Possible solutions
External Terminal Stop Error 	<ul style="list-style-type: none"> Remove the run command from external terminal
EPErr EEPROM Save error 	<ul style="list-style-type: none"> Restore factory setting, then cut off the power and power on again. If warning again, replace control board.
bdErr Control board error 	Replace the control board.
Wrong running direction Error 	Revise the command among 11-00, jog and DI control to see if any difference
Parameter Lock 	Lifting the parameter lock key code, to enter the correct parameter for 13-07
Set password failed 	Enter the correct parameter for 13-07 to enable the parameter lock key
Run Command Error 	Remove the reverse operation command from external terminal
ES (flash) External Emergency Stop 	Turn off run command, and remove external emergency stop command.
Zero Speed Stop Error 	Adjust frequency command

Warning Message (LCD display only)

LCD Display	Possible solutions
Operator Copy Error RDE	Check operator and control connection
Operator Write Error WRE	Check the control mode, model name and firmware version of inverter.
Operator Compare Error VRYE	Check operator and control connection
Does Not Allow to Read and Save Data RDP	Check parameter setting of parameter (16-08)

第 1 章 安全注意事項

1.1 送電前

警告

- 主回路端子必須正確配線，單相 L1(L)、L3(N)、三相 L1(L)、L2、L3(N)為電源輸入端子，絕對不可以與 T1、T2、T3 混用；混用時，送電將造成變頻器的損壞。

注意

- 所選用之電源電壓必須與變頻器之輸入電壓規格相同。
- 搬運變頻器時，請勿直接提取前蓋，應由變頻器本體搬運，以防止前蓋脫落，避免變頻器掉落造成人員受傷或變頻器損壞。
- 請將變頻器安裝於金屬類等不燃物材料之上，請勿安裝於易燃性材料上或附近，以防止發生火災。
- 若多台變頻器同放在一個控制盤內，請外加散熱風扇，使盤內溫度低於 40°C 以下(無防塵蓋 50°C以下)，以防過熱或火災等發生。
- 請於關閉電源後，再拆卸或裝入操作器，並請按圖操作固定操作器，以免接觸不良造成操作器故障或不顯示。
- 本產品所提供的電源(10V/24V)僅供產品內部接點使用，請勿使用於其他外部元件的電源供應來源，如 感應器、電子元件...等，否則會造成產品使用不良的情況。

警告

- 本產品系通過 IEC 61800-3 和 IEC 61800-5-1 限制區域使用等級。在某些環境下使用本產品時，可能造成電磁干擾，在使用前請先進行適當的測試，同時請務必做好接地工程。
- 本產品提供馬達過溫度保護功能。

注意

- 產品的安裝及使用必須由有資格的專業電氣人員進行。
- 產品的安裝必須以固定式配線方式進行。

1.2 送電中

警告

- 實施任何變頻器裝機或配線前，請務必關上總電源，避免觸電及火災發生。
- 配線工程人員須具備相關專業知識，避免觸電與火災發生。
- 確認接地線與大地連接。(220V 級:接地阻抗需低於 100 歐姆; 440V 級:接地阻抗需低於 10 歐姆)，請依據 EN61800-5-1 規範要求將變頻器接地。電線尺寸線徑需達 10mm (6AWG)方可符合限制洩漏電流之標準。
- RCD 須符合 B 型漏電流之保護規範。
- 接線完成後，確認緊急停止機能有效。(接線責任屬於使用方)
- 勿直接觸碰輸入/輸出電源線，並避免所有接線與變頻器外殼接觸與線路短路。
- 勿對變頻器進行耐壓測試，容易造成半導體元件受損。

注意

- 確認輸入主電源與變頻器相符，避免受傷或火災發生。
- 請依相關接線圖連接煞車電阻及煞車單元，否則有引發火災危險。
- 請依指定轉矩來鎖固端子螺絲，避免引發火災的危險。
- 勿將輸入電源連接至變頻器輸出端子上。
- 勿將電磁接觸器，電磁開關接點連接至輸出端子。
- 勿將進相電容器或 LC/RC 濾波器連接至輸出電路上。
- 確保變頻器、馬達所產生的干擾不會影響周邊感測器或設備。

警告

- 若停電時間大於兩秒(功率越大，可允許斷電時間愈長)，會使變頻器失去控制電源，故在電源恢復送電以後，變頻器運行與否，是根據 00- 02(或 00- 03)及 07- 04 參數的設定及外部開關的狀態而決定，此時視為重新開機。
- 若停電時間短，變頻器仍擁有控制電源，因此當電源恢復時，變頻器能否自行啟動，將取決於 07- 00 參數的設定。
- 當重新開機時，變頻器運轉與否，取決於 00- 02(或 00- 03)及 07- 04 的設定及電源開關/運轉開關(FWD/REV 開關)的狀態(與 07- 00/07- 01/07- 02)：
 1. 00- 02(或 00- 03)=0 時，重新開機後，不會自動啟動。
 2. 00- 02(或 00- 03)=1 且電源開關或運轉開關(FWD/REV 開關)關斷時，重新開機後，不會自動啟動。
 3. 00- 02(或 00- 03)=1 且電源開關及運轉開關導通且 07- 04=0 時，重新開機後，會自動啟動。基於安全考慮，請在停電以後將電源開關及運轉開關(FWD/REV 開關)關斷，以避免突然復電後，對機器及人身造成傷害。
- 07- 04=0 時，為確保人身及機器設備安全，請參照 07- 04 詳細使用說明及建議。

1.3 運轉前

警告

- 送電前請確認，變頻器機種與變頻器功能參數 13- 00 所設定之機種容量相同。
- 變頻器與馬達間線長超過 25 公尺，需降低載波頻率(11-01)或加裝輸出濾波器來降低負載端過電壓或振盪，避免馬達受損。

注意

- 電源投入時，變頻器會先閃爍 01- 14 所設定的變頻器供電電源電壓 2 秒。
- 使用旋轉型自動調校時，請勿將馬達連接到負載(機械設備)上。
- 進行旋轉型自動調校時，馬達將進行旋轉，請確認與馬達連接之設備運轉範圍安全，避免造成危險。

1.4 運轉中

警告

- 請確認前外蓋安裝完成後，再打開電源。
- 運轉中不可將馬達機組投入或切離，否則會造成變頻器過電流跳脫，嚴重時會造成變頻器主回路損壞。
- 進行復歸機能時，請勿靠近機器，故障清除後，機器會再啟動。
- 勿於雙手潮濕時操作機器。
- 如設定自動再啟動功能時，馬達於運轉停止後會自動再啟動，請勿靠近機器以免危險。
- 復歸警告前請確認運轉命令為關閉的。
- 若選擇復電後自動重新啟動(07-00)，變頻器將在電源回復後自動啟動。
- 無論變頻器處於運轉或停止狀態，避免觸碰相關端子，以防發生危險。
- 避免感電！變頻器內部的直流電容器在電源移除後 5 分鐘才能放電完畢，請在電源移除 5 分鐘後，再進行拆裝或實施檢查。(15HP 以上需等待 15 分鐘)

注意

- 散熱座、煞車電阻等發熱元件請勿觸摸。
- 變頻器可以很容易使馬達從低速到高速運轉，請確認馬達與機械的容許範圍。
- 使用煞車模組等搭配產品時，請注意其使用之相關設定。
- 電源切斷後，風扇可能會繼續旋轉一段時間。
- 變頻器運轉時，請勿檢查電路板上的信號。

1.5 檢查保養和更換時

警告

- 進行維護檢查前，請先確認電源已經關閉且電源指示燈已熄滅。
(請確認直流電壓不超過 25 伏特)。
- 變頻器端子中有高壓端子，請勿隨意觸摸。
- 電源開啟情況下，請務必安裝保護蓋，另拆卸保護蓋後，請務必透過斷路器斷開電源。
- 除指定的專業人員外，他人請勿進行保養檢查或更換零件。

注意

- 變頻器周圍溫度應在 $-10^{\circ}\text{C}\sim+50^{\circ}\text{C}$ * 95%RH 不結露環境中使用，但需確保周圍環境無滴水及金屬粉塵。

* $-10^{\circ}\text{C}\sim+50^{\circ}\text{C}$ (適用於無防塵蓋/防塵貼紙之產品)

$-10^{\circ}\text{C}\sim+40^{\circ}\text{C}$ (適用於有防塵蓋/防塵貼紙之產品)

1.6 變頻器報廢時注意事項

注意

當變頻器要處理報廢時，請作為工業垃圾進行處理，並請注意以下事項：

- 變頻器主回路的電解電容和印刷電路板上的電解電容焚燒時可能會發生爆炸；
- 變頻器的外殼等塑膠件焚燒時會產生有毒氣體。



裝有電子元件的設備不能與生活垃圾一起處理，必須按照地方現行法規將其與電氣和電子廢棄物一起單獨回收。

1.7 保證責任的免除

因本公司產品的故障，給貴公司或貴公司的客戶等造成的機會喪失以及非本公司產品的損傷，或對於其他業務的補償，無論是否在保證期限內，均不屬於本公司的保證範圍。

第 2 章 周圍環境及安裝

2.1 系統圖：



2.2 標準配線

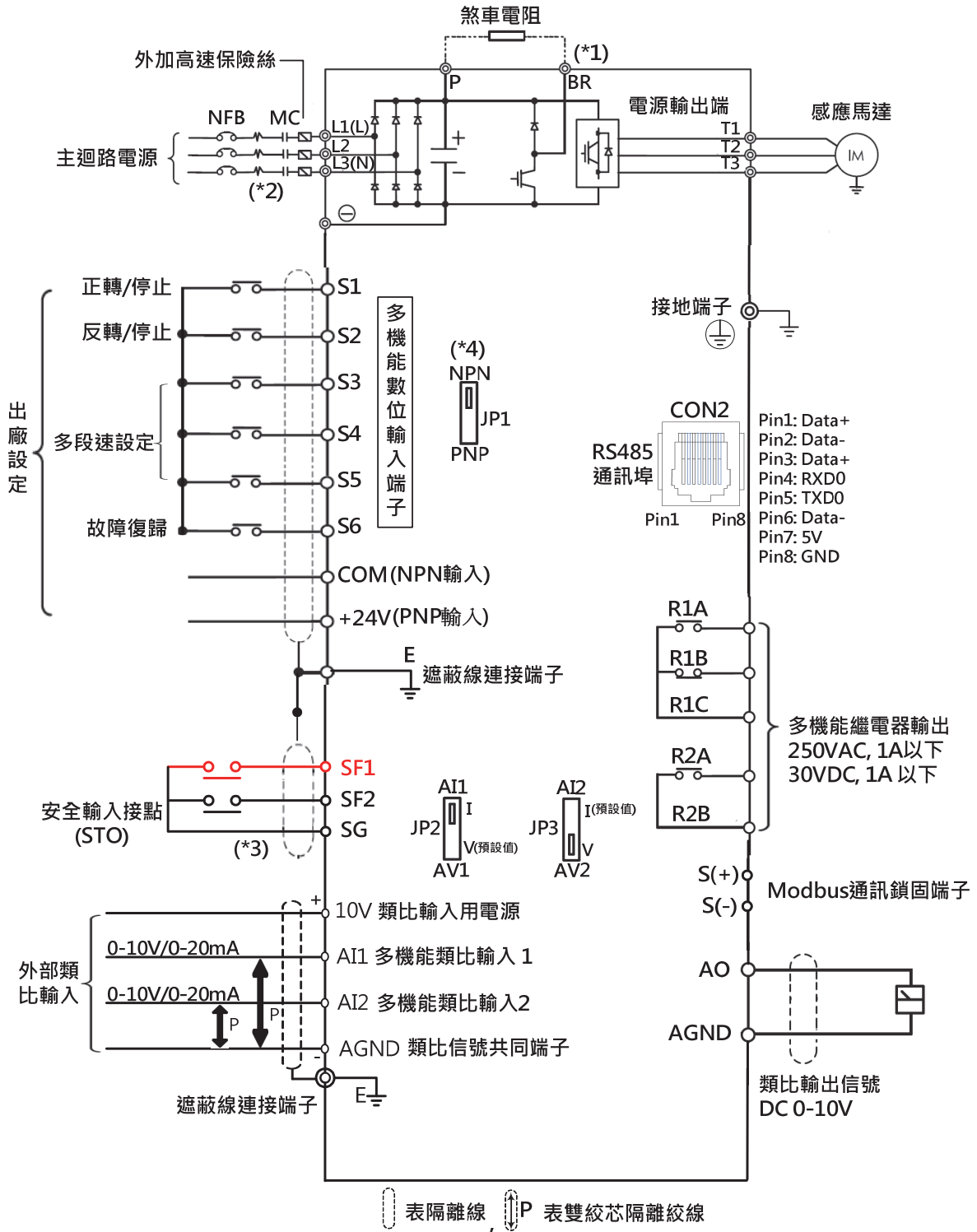

備註說明：

(*1) 200V 0.5-25HP與400V 1-40HP可直接於P/BR連接煞車電阻，其餘機種需選購煞車模組。

(*2) 建議客戶加裝斷路保護線路，可於電源異常時將電源斷開，保護變頻器。

單相輸入機種請由L1(L)/L3(N)端點連接電源輸入端

(*3) 安全輸入接點(SF/SG)間需短接，變頻器方可正常輸出。如需使用安全輸入功能，請務必移除SF/SG間之短接線。

(*4) 多機能數位輸入接點S1-S6，可透過JP1開關設定為NPN(連接COM共點)，或PNP(連接+24V共點)輸入。

2.3 端子說明

2.3.1 主迴路端子說明

端子符號	TM1 端子功能說明
L1(L)	交流電源輸入端：單相：L1(L)、L3(N) 單/三相：L1(L)、L2、L3(N) 三相：L1、L2、L3
L2	
L3(N)	
T1/T2/T3	變頻器的輸出端，連接馬達 U、V、W 端
P	剎車電阻連接端子，當負載慣量大或減速時間短，而使變頻器容易過電壓跳脫時使用（參照剎車電阻規格）
BR	
	接地端子

控制迴路端子：

R2A	R2B	R1A	R1B	R1C		S1	S3	S5	24V	AI1	AI2
S(+)	S(-)	SF1	SG	SF2	COM	S2	S4	S6	AGND	10V	AO

2.3.2 控制迴路端子說明

種類	端子	端子功能	信號準位
數位輸入信號	S1	有關數位輸入端子預設功能與設定範圍，請參閱參數群組 3 之說明	24 VDC, 8 mA 光耦合隔離(最大電壓 30 Vdc, 輸入阻抗 4.3kΩ)
	S2		
	S3		
	S4		
	S5		
	S6		
繼電器輸出	R1A	常開接點	250VAC/1A(30VDC/1A)
	R1B	常閉接點	
	R1C	共同端子	
	R2A	常開接點	
	R2B		
24V 電源供應	24V	端子 S1~S6 信號的共同端子(JP1 切至 PNP 位置)	±15%,最大輸出電流 60mA
	COM	端子 S1~S6 信號的共同端子(JP1 切至 NPN 位置)	
類比輸入信號	10V	速度設定用電源	10V(最大電流, 20mA)
	AI1	多功能類比輸入可用 JP2 切換電壓或電流輸入 *2 電壓：JP2 切至 AV1 位置 電流：JP2 切至 AI1 位置	電壓輸入，阻抗：153KΩ 電流輸入：阻抗：500Ω
	AI2	多功能類比輸入可用 JP3 切換電壓或電流輸入 *2 電壓：JP3 切至 AV2 位置 電流：JP3 切至 AI2 位置	
	AGND	類比信號共同端子	----
		遮蔽線連接端子 (大地)	----
類比輸出信號	AO	多功能類比輸出端子	0 到 10V,(最大電流:2mA)
	AGND	類比信號共同端子	----
安全開關	SF1,SF2	SF 為安全開關，出廠時為常閉接點，當狀態改變為常開接點時，將切斷變頻器輸出電壓	SF1/SF2 專用之 24V
	SG		
Modbus 通訊	S(+)	Modbus 通訊鎖固端子(波特率設定 9600~38400)	
	S(-)		

第 3 章 軟體索引

3.1 參數一覽表

參數群組	名 稱
群組 00	基本功能群組
群組 01	V/F 控制功能群組
群組 02	IM 馬達參數群組
群組 03	外部端子數位輸入輸出功能群組
群組 04	外部端子類比輸入輸出功能群組
群組 05	多段速功能群組
群組 06	自動運轉功能群組
群組 07	運轉停止功能群組
群組 08	保護功能群組
群組 09	通訊功能群組
群組 10	PID 功能群組
群組 11	輔助功能群組
群組 12	監視功能群組
群組 13	維護功能群組
群組 14	PLC 設定群組
群組 15	PLC 監控群組
群組 16	LCD 機能群組
群組 17	自動調校功能群組
群組 18	滑差補償功能群組
群組 20	速度控制功能群組
群組 21	轉矩限制功能群組
群組 22	PM 馬達群組
群組 23	恆壓 PUMP 功能群組

參數屬性	
*1	運轉中可修改的參數
*2	保留
*3	在做出廠設定時，此參數的值(用戶設定的值)不會恢復為出廠預設值
*4	參數唯讀不可修改
*5	需搭配選配卡時，參數才會顯示
*6	僅使用 LED 數位操作器時顯示
*7	僅使用 LCD 數位操作器時顯示
*8	其設定值將依 13-08 之設定而變更

群組 00 基本功能群組				
代碼	參數名稱	範圍	出廠設定	屬性
00-00	控制模式	0:V/F	0	*3
		2:SLV		
		5:PMSLV		
00-01	馬達轉向	0:正轉 1:反轉	0	*1
00-02	主運轉命令來源選擇	0:按鍵面板	1	
		1:外控		
		2:通訊控制 3:PLC		
00-03	副運轉命令來源選擇	0:按鍵面板	0	
		1:外控		
		2:通訊控制 3:PLC		
00-04	多功能端子運轉模式選擇	0:正轉/停止-反轉/停止	0	
		1:運轉/停止-正轉/反轉		
		2:3線制運轉/停止		
00-05	主頻率命令來源選擇	0:按鍵面板上下鍵給定	2	
		1:按鍵面板旋鈕給定		
		2:外部端子 AI1 給定		
		3:外部端子 AI2 給定		
		4:外部端子 UP/DOWN 給定		
		5:通訊控制給定		
		6:保留		
7:脈衝輸入調速				
00-06	副頻率命令來源選擇	0:按鍵面板上下鍵給定	0	
		1:按鍵面板旋鈕給定		
		2:外部端子 AI1 給定		
		3:外部端子 AI2 給定		
		4:外部端子 UP/DOWN 給定		
		5:通訊控制給定		
		6:保留		
7:脈衝輸入調速				
00-07	頻率源組合模式選擇	0:主頻率源與副頻率源切換	0	
		1:主頻率源+副頻率源		
00-08	通訊頻率命令	0.00~599.00	0.00	*4
00-09	頻率命令記憶模式	0:不記憶斷電前通訊頻率命令	0	
		1:記憶斷電前通訊頻		

群組 00 基本功能群組				
代碼	參數名稱	範圍	出廠設定	屬性
		率命令		
00-10	停機時初始頻率命令模式	0:依目前頻率命令	0	
		1:頻率命令歸零		
		2:依參數 00-11 設定值		
00-11	停機時初始頻率命令設定	0.00-599.00	-	*1
00-12	頻率上限	0.01-599.00	0.0	
00-13	頻率下限	0.00-599.00	0.0	
00-14	加速時間 1	0.1~6000.0	*	*1
00-15	減速時間 1	0.1~6000.0	*	*1
00-16	加速時間 2	0.1~6000.0	*	*1
00-17	減速時間 2	0.1~6000.0	*	*1
00-18	寸動頻率	0.00~599.00	2.00	*1
00-19	寸動加速時間	0.1~0600.0	*	*1
00-20	寸動減速時間	0.1~0600.0	*	*1
00-21	加速時間 3	0.1~6000.0	*	*1
00-22	減速時間 3	0.1~6000.0	*	*1
00-23	加速時間 4	0.1~6000.0	*	*1
00-24	減速時間 4	0.1~6000.0	*	*1
00-26	緊急停止時間	0.1~6000.0	5.0	
00-27	HD/ND 模式選擇 (F5/6 有此功能)(***)	0: HD 重負載模式	0	*3
		1: ND 標準負載模式		
00-34	語言選擇	0: 英文	0	*7
		1: 簡體中文		
		2: 繁體中文		
		3: 土耳其文		
00-35	最小頻率檢測動作	0: 低於最小頻率會跳警告	0	
		1: 低於最小頻率以最小頻率運轉		
00-36	PID 頻率下限選擇	0: 無效(PID 休眠限制頻率下限)	0	
		1: 有效(PID 休眠限制 0Hz)		

* : 參考附件一(加減速時間初始值)

*** : 00-27 若設定為 ND 模式, 02 群組的馬達 1 參數會自動變更為大一級的馬達參數。

00-27 設定為 HD 模式, 02 群組的馬達 1 參數會自動變更為同級的馬達參數。

00-27 會自動變更馬達參數, 因此建議在進行馬達自動調校前設定。

**** : 馬達最大輸出頻率超過 300Hz 時, 頻率解析度為 0.1Hz

群組 01 V/F 控制功能群組				
代碼	參數名稱	範圍	出廠設定	屬性
01-00	V/F 曲線選擇	0~FF	F	*3
01-02	馬達 1 最大輸出頻率	4.8~599.0	50.0/60.0	*8
01-03	馬達 1 最大輸出電壓	200V: 0.1~255.0 400V: 0.2~510.0	230.0 400.0	*8
01-04	馬達 1 中間輸出頻率 2	0.0~599.0	0.0	
01-05	馬達 1 中間輸出電壓 2	200V: 0.0~255.0 400V: 0.0~510.0	0.0	
01-06	馬達 1 中間輸出頻率 1	0.0~599.0	2.5/3.0	*8
01-07	馬達 1 中間輸出電壓 1	200V: 0.0~255.0 400V: 0.0~510.0	KVA	*8
01-08	馬達 1 最小輸出頻率	0.0~599.0	VF : 1.3/1.5 SLV : 0.5/0.6 PMS LV : 10.0	
01-09	馬達 1 最小輸出電壓	200V: 0.0~255.0 400V: 0.0~510.0	KVA	*8
01-10	轉矩補償增益 (V/F 曲線修正)	0.0~2.0	0.5	*1
01-11	轉矩補償模式選擇	0: 模式 0(一般補償) 1: 模式 1(高速補償)	0	
01-12	馬達 1 基底頻率	4.8~599.0	50.0/60.0	*8
01-13	馬達 1 基底輸出電壓	200V: 0.0~255.0 400V: 0.0~510.0	230.0 400.0	*8
01-14	輸入電壓設定	200V: 55.0~255.0 400V: 10.0~510.0	230.0 400.0	*8
01-15	轉矩補償時間	0~10000	200	
01-16	馬達 2 最大輸出頻率	4.8~599.0	50.0/60.0	*8
01-17	馬達 2 最大輸出電壓	200V: 0.1~255.0 400V: 0.2~510.0	230.0 400.0	*8
01-18	馬達 2 中間輸出頻率 2	0.0~599.0	0.0	
01-19	馬達 2 中間輸出電壓 2	200V: 0.0~255.0 400V: 0.0~510.0	0.0	
01-20	馬達 2 中間輸出頻率 1	0.0~599.0	2.5/3.0	*8
01-21	馬達 2 中間輸出電壓 1	200V: 0.0~255.0 400V: 0.0~510.0	KVA	*8

群組 01 V/F 控制功能群組				
代碼	參數名稱	範圍	出廠設定	屬性
01-22	馬達 2 最小輸出頻率	0.0~599.0	1.3/1.5	
01-23	馬達 2 最小輸出電壓	200V: 0.0~255.0 400V: 0.0~510.0	KVA	*8
01-24	馬達 2 基底頻率	4.8~599.0	50.0/60.0	*8
01-25	馬達 2 基底輸出電壓	200V: 0.0~255.0 400V: 0.0~510.0	230.0 400.0	*8
01-26	馬達 2 V/F 曲線選擇	0~FF	F	*3

KVA：該參數會隨著不同變頻器的容量大小而不同。

群組 02 IM 馬達參數群組				
代碼	參數名稱	範圍	出廠設定	屬性
02-00	馬達 1 無載電流	0.01~600.00	KVA	
02-01	馬達 1 額定電流	下限：10%變頻器額定(VF) 25%變頻器額定(SLV) 上限：依變頻器容量而定	KVA	
02-03	馬達 1 額定轉速	0~60000	KVA	*8
02-04	馬達 1 額定電壓	200V: 50.0~240.0 400V: 100.0~480.0	230.0 400.0	*8
02-05	馬達 1 額定功率	0.01~600.00	KVA	
02-06	馬達 1 額定頻率	4.8~599.0	50.0/60.0	*8
02-07	馬達 1 極數	2~16(偶數)	4	
02-09	馬達 1 激磁電流	15%~70%馬達額定電流	KVA	
02-10	馬達 1 鐵心飽和係數 1	1~100	KVA	
02-11	馬達 1 鐵心飽和係數 2	1~100	KVA	
02-12	馬達 1 鐵心飽和係數 3	80~300	KVA	
02-13	馬達 1 鐵心損失	0.0~15.0	KVA	
02-15	馬達 1 線間電阻	1~60.000	KVA	

群組 02 IM 馬達參數群組				
代碼	參數名稱	範圍	出廠設定	屬性
02-16	馬達 1 轉子電阻	1~60.000	KVA	
02-17	馬達 1 漏感	0.001~60.000	KVA	
02-19	馬達 1 無載電壓	200V: 50~240 400V: 100~480	-	*8
02-20	馬達 2 無載電流	0.01~600.00	KVA	
02-21	馬達 2 額定電流	10%變頻器額定~ 依變頻器容量	KVA	
02-22	馬達 2 額定轉速	0~60000	KVA	*8
02-23	馬達 2 額定電壓	200V: 50.0~240.0 400V: 100.0~480.0	230.0 400.0	*8
02-24	馬達 2 額定功率	0.01~600.00	KVA	
02-25	馬達 2 額定頻率	4.8~599.0	50.0/ 60.0	*8
02-26	馬達 2 極數	2~16(偶數)	4	
02-32	馬達 2 線間電阻	0.001~60.000	KVA	
02-33	馬達漏感比例	0.1~15.0	KVA	
02-34	馬達滑差頻率	0.10~20.00	KVA	

群組 03 外部端子數位輸入輸出功能群組				
代碼	參數名稱	範圍	出廠設定	屬性
03-00	多功能端子 S1 功能設定	0: 正轉/停止	0	
		1: 反轉/停止		
		2: 多段速/位置設定指令 1		
		3: 多段速/位置設定指令 2		
		4: 多段速/位置設定指令 3		
		5: 多段速/位置設定指令 4		
03-01	多功能端子 S2 功能設定	6: 寸動正轉指令	1	
		7: 寸動反轉指令		
		8: UP 增頻率指令		
		9: DOWN 減頻率指令		
		10: 加/減速時間選擇 2		
		11: 加/減速禁止		

群組 03 外部端子數位輸入輸出功能群組				
代碼	參數名稱	範圍	出廠設定	屬性
03-02	多功能端子 S3 功能設定	12: 主/副運轉命令 切換	2	
		13: 主/副頻率命令 切換		
		14: 緊急停止(減速 到零停止)		
		15: 遮斷停止(自由 運轉停止)		
		16: PID 功能禁止		
		17: 故障復歸 (RESET)		
03-03	多功能端子 S4 功能設定	18: 自動程式運轉	3	
		19: 速度搜尋指令 1		
		20: 省能運行(僅 V/F)		
		21: PID 積分器復 歸		
		22: 計數器觸發信 號輸入		
		23: 計數器清零指 令		
03-04	多功能端子 S5 功能設定	24: PLC 應用	4	
		25: 脈衝輸入-脈衝 寬度測量 (S3)		
		26: 脈衝輸入-脈衝 頻率測量 (S3)		
		27: 本體/遠端選擇		
03-05	多功能端子 S6 功能設定	28: 遠端模式選擇	17	
		29: 寸動頻率選擇		
		30: 直流煞車指令		
		31: 速度搜尋指令 2		
		32: 馬達 1/馬達 2 切換		
		33: PID 休眠		
03-06	UP/DOWN 頻率幅寬設定	34: 火災模式輸入	0.00~5.00	
		35: KEB 加速指令		
		36: 強制頻率運轉		
		37: 切換恆壓誤差 2		
		38: 短路煞車指令		
		39: PID 功能禁止 2		
03-06	UP/DOWN 頻率幅寬設定	40: 外部故障	0.00~5.00	
		41: 外部過載		

群組 03 外部端子數位輸入輸出功能群組				
代碼	參數名稱	範圍	出廠設定	屬性
03-07	UP/DOWN 頻率保持選擇	0: 停止時保持 UP/DOWN 頻率	0	
		1: 停止時清除 UP/DOWN 頻率		
		2: 停止時允許頻率 UP/DOWN		
		3: 加速時更新頻率。		
03-08	(S1~S6)DI 掃瞄時間	1~200	1	
03-09	多功能端子 S1-S4 類型選擇	xxx0b:S1 A 接點	0000b	
		xxx1b:S1 B 接點		
		xx0xb:S2 A 接點		
		xx1xb:S2 B 接點		
		x0xxb:S3 A 接點		
		x1xxb:S3 B 接點		
03-10	多功能端子 S5-S6 類型選擇	0xxx b:S4 A 接點	0000b	
		1xxx b:S4 B 接點		
		xxx0b:S5 A 接點		
		xxx1b:S5 B 接點		
03-11	繼電器 (R1A-R1C)輸出	xxx0xb:S6 A 接點	1	
		xxx1b:S6 B 接點		
		xx0xb:S6 A 接點		
		xx1xb:S6 B 接點		
		0: 運轉中		
		1: 故障指示		
		2: 設定頻率到達		
		3: 任意頻率到達 (03-13±03-14)		
		4: 頻率檢出 1 (輸出頻率≥ (03-13+03-14))		
		5: 頻率檢出 2 (輸出頻率≤ (03-13+03-14))		
		6: 自動再啟動		
		7: 瞬停動作		
		8: 緊急停止		
		9: 遮斷停止		
		10: 馬達超載保護 (OL1)		
11: 變頻器超載保護(OL2)				
12: 過轉矩檢出 (OT)				
13: 電流到達				
14: 機械剎車控制功能				
15: PID 回饋斷線檢出				

群組 03 外部端子數位輸入輸出功能群組				
代碼	參數名稱	範圍	出廠設定	屬性
		16: 設定計數值到達指示(3-22~23)		
		17: 指定計數值到達指示(3-22~23)		
		18: PLC 狀態指示 (00-02)		
		19: PLC 控制*		
		20: 零速功能		
		30: 選擇馬達 2		
		37: PID 回授斷線偵測輸出		
		54: 短路煞車中		
03-12	繼電器 (R2A-R2B)輸出	55: 低電流輸出	0	
		59: OH 偵測		
03-13	任意頻率到達設定	0.0~599.0	0.0	
03-14	頻率輸出偵測範圍(±)	0.1~25.5	2.0	
03-15	電流到達準位	0.1~999.9	0.1	
03-16	電流到達檢測延遲時間	0.1~10.0	0.1	
03-17	*機械煞車釋放準位設定	0.00~20.00	0.00	
03-18	*機械煞車動作準位設定	0.00~20.00	0.00	
03-19	繼電器(R1A-R2B)類型選擇	xxx0b: R1 A 接點	0000b	
		xxx1b: R1 B 接點		
		xx0xb: R2 A 接點		
		xx1xb: R2 B 接點		
03-20	內部/外部多功能輸入端子選擇	0~63	0	
03-21	內部多功能輸入端子動作設定	0~63	0	
03-22	計數值到達設定	0~9999	0	
03-23	指定計數值到達設定	0~9999	0	
03-24	低電流檢出設定	0: 無效 1: 有效	0	
03-25	低電流檢出準位	0~999.9	0.1	
03-26	低電流檢出延遲時間	0.0~655.34	0.01	
03-27	脈衝輸入刻度	50~25000	200	*1
03-28	脈衝輸入增益	0.0~1000.0	100.0	*1

群組 03 外部端子數位輸入輸出功能群組				
代碼	參數名稱	範圍	出廠設定	屬性
03-29	光耦輸出類型選擇	xxx0b: 光耦 A 接點 xxx1b: 光耦 B 接點	0000 b	
03-30	脈波輸入選擇	0: 一般脈波輸入 1: PWM 方式 2: PLC 編碼器輸入	0	
03-33	脈波輸入偏壓	-100.0~100.0	0.0	*1
03-34	脈波輸入濾波時間	0.00~2.00	0.1	*1
03-53	電流到達準位 2	0.0~999.9	0.1	
03-54	緊急停止動作	關閉運轉指令及緊急停止指令後 0: 待變頻器完全停止才能重新啟動 1: 需額外重置指令才能重新啟動	0	

* : 馬達最大輸出頻率超過 300Hz 時，頻率解析度為 0.1Hz

群組 04 外部端子類比輸入輸出功能群組				
代碼	參數名稱	範圍	出廠設定	屬性
04-00	AI 輸入信號種類	0: AI1:0~10V AI2: 0~10V / 0~20mA 1: AI1:0~10V AI2: 4~20mA / 2~10V 2: AI1: 2~10V AI2: 0~10V / 0~20mA 3: AI1: 2~10V AI2: 4~20mA / 2~10V	1	
04-01	AI1 信號掃描濾波時間	0.00~2.00	0.03	
04-02	AI1 增益值	0.0~1000.0	100.0	*1
04-03	AI1 偏壓值	-100.0~100.0	0	*1
04-05	AI1 信號方向控制選擇	0 : 正向 1 : 負向	0	
04-06	AI2 信號掃描濾波時間	0.00~2.00	0.03	
04-07	AI2 增益值	0.0~1000.0	100.0	*1
04-08	AI2 偏壓值	-100.0~100.0	0	*1
04-10	AI2 信號方向控制選擇	0 : 正向 1 : 負向	0	
04-11	AO 功能設定	0: 輸出頻率	0	

群組 04 外部端子類比輸入輸出功能群組				
代碼	參數名稱	範圍	出廠設定	屬性
		1: 頻率指令 2: 輸出電壓 3: 直流電壓 4: 輸出電流		
04-12	AO 增益值	0.0~1000.0	100.0	*1
04-13	AO 偏壓值	-100.0~100.0	0	*1
04-15	AO 信號方向控制選擇	0 : 正向 1 : 負向	0	
04-16	比例連動功能	0 : 無效 1 : 有效	0	
04-20	AO 信號掃描濾波時間	0.00~0.50	0.00	*1
04-22	AO 電壓校正選擇	0 : 無效 1 : 有效	0	

群組 05 多段速功能群組				
代碼	參數名稱	範圍	出廠設定	屬性
05-00	多段速加減速模式選擇	0: 段速加減速時間由加減速時間 1~4 設定 1: 段速加減速時間獨立設定	0	
05-01	*第 0 段速頻率設定	0.00~599.00	5.00	*1
05-02	*第 1 段速頻率設定	0.00~599.00	5.00	*1
05-03	*第 2 段速頻率設定	0.00~599.00	10.00	*1
05-04	*第 3 段速頻率設定	0.00~599.00	20.00	*1
05-05	*第 4 段速頻率設定	0.00~599.00	30.00	*1
05-06	*第 5 段速頻率設定	0.00~599.00	40.00	*1
05-07	*第 6 段速頻率設定	0.00~599.00	50.00	*1
05-08	*第 7 段速頻率設定	0.00~599.00	50.00	*1
05-09	*第 8 段速頻率設定	0.00~599.00	5.00	*1
05-10	*第 9 段速頻率設定	0.00~599.00	5.00	*1
05-11	*第 10 段速頻率設定	0.00~599.00	5.00	*1
05-12	*第 11 段速頻率設定	0.00~599.00	5.00	*1
05-13	*第 12 段速頻率設定	0.00~599.00	5.00	*1
05-14	*第 13 段速頻率設定	0.00~599.00	5.00	*1

群組 05 多段速功能群組				
代碼	參數名稱	範圍	出廠設定	屬性
05-15	*第 14 段速頻率設定	0.00~599.00	5.00	*1
05-16	*第 15 段速頻率設定	0.00~599.00	5.00	*1
05-17	多段速 0 加速時間設定	0.1~6000.0	10.0	
05-18	多段速 0 減速時間設定	0.1~6000.0	10.0	
05-19	多段速 1 加速時間設定	0.1~6000.0	10.0	
05-20	多段速 1 減速時間設定	0.1~6000.0	10.0	
05-21	多段速 2 加速時間設定	0.1~6000.0	10.0	
05-22	多段速 2 減速時間設定	0.1~6000.0	10.0	
05-23	多段速 3 加速時間設定	0.1~6000.0	10.0	
05-24	多段速 3 減速時間設定	0.1~6000.0	10.0	
05-25	多段速 4 加速時間設定	0.1~6000.0	10.0	
05-26	多段速 4 減速時間設定	0.1~6000.0	10.0	
05-27	多段速 5 加速時間設定	0.1~6000.0	10.0	
05-28	多段速 5 減速時間設定	0.1~6000.0	10.0	
05-29	多段速 6 加速時間設定	0.1~6000.0	10.0	
05-30	多段速 6 減速時間設定	0.1~6000.0	10.0	
05-31	多段速 7 加速時間設定	0.1~6000.0	10.0	
05-32	多段速 7 減速時間設定	0.1~6000.0	10.0	
05-33	多段速 8 加速時間設定	0.1~6000.0	10.0	
05-34	多段速 8 減速時間設定	0.1~6000.0	10.0	
05-35	多段速 9 加速時間設定	0.1~6000.0	10.0	
05-36	多段速 9 減速時間設定	0.1~6000.0	10.0	
05-37	多段速 10 加速時間設定	0.1~6000.0	10.0	
05-38	多段速 10 減速時間設定	0.1~6000.0	10.0	
05-39	多段速 11 加速時間設定	0.1~6000.0	10.0	
05-40	多段速 11 減速時間設定	0.1~6000.0	10.0	
05-41	多段速 12 加速時間設定	0.1~6000.0	10.0	
05-42	多段速 12 減速時間設定	0.1~6000.0	10.0	
05-43	多段速 13 加	0.1~6000.0	10.0	

群組 05 多段速功能群組				
代碼	參數名稱	範圍	出廠設定	屬性
	速時間設定			
05-44	多段速 13 減速時間設定	0.1~6000.0	10.0	
05-45	多段速 14 加速時間設定	0.1~6000.0	10.0	
05-46	多段速 14 減速時間設定	0.1~6000.0	10.0	
05-47	多段速 15 加速時間設定	0.1~6000.0	10.0	
05-48	多段速 15 減速時間設定	0.1~6000.0	10.0	

* : 馬達最大輸出頻率超過 300Hz 時, 頻率解析度為 0.1Hz

群組 06 自動運轉功能群組				
代碼	參數名稱	範圍	出廠設定	屬性
06-00	自動運轉模式選擇	0: 無效	0	
		1: 執行單一週期運轉模式, 停止後會由停止前的速度繼續運轉		
		2: 連續週期運轉模式, 停止後會由停止前的速度繼續運轉		
		3: 單一週期結束後, 以最後一段運轉速度繼續運轉, 停止後會由停止前的速度繼續運轉		
		4: 執行單一週期運轉模式, 停止後會從第零段速起開始運轉		
		5: 連續週期運轉模式, 停止後會從第零段速起開始運轉		
		6: 單一週期結束後, 以最後一段運轉速度繼續運轉, 停止後會從第零段速起開始運轉		
06-01	*第 1 段運轉頻率設定	0.00~599.00	0.0	*1
06-02	*第 2 段運轉頻率設定	0.00~599.00	0.0	*1

群組 06 自動運轉功能群組				
代碼	參數名稱	範圍	出廠設定	屬性
06-03	*第3段運轉頻率設定	0.00~599.00	0.0	*1
06-04	*第4段運轉頻率設定	0.00~599.00	0.0	*1
06-05	*第5段運轉頻率設定	0.00~599.00	0.0	*1
06-06	*第6段運轉頻率設定	0.00~599.00	0.0	*1
06-07	*第7段運轉頻率設定	0.00~599.00	0.0	*1
06-08	*第8段運轉頻率設定	0.00~599.00	0.0	*1
06-09	*第9段運轉頻率設定	0.00~599.00	0.0	*1
06-10	*第10段運轉頻率設定	0.00~599.00	0.0	*1
06-11	*第11段運轉頻率設定	0.00~599.00	0.0	*1
06-12	*第12段運轉頻率設定	0.00~599.00	0.0	*1
06-13	*第13段運轉頻率設定	0.00~599.00	0.0	*1
06-14	*第14段運轉頻率設定	0.00~599.00	0.0	*1
06-15	*第15段運轉頻率設定	0.00~599.00	0.0	*1
06-16	第0段運轉時間設定	0.0~6000.0	0.0	*1
06-17	第1段運轉時間設定	0.0~6000.0	0.0	*1
06-18	第2段運轉時間設定	0.0~6000.0	0.0	*1
06-19	第3段運轉時間設定	0.0~6000.0	0.0	*1
06-20	第4段運轉時間設定	0.0~6000.0	0.0	*1
06-21	第5段運轉時間設定	0.0~6000.0	0.0	*1
06-22	第6段運轉時間設定	0.0~6000.0	0.0	*1
06-23	第7段運轉時間設定	0.0~6000.0	0.0	*1
06-24	第8段運轉時間設定	0.0~6000.0	0.0	*1
06-25	第9段運轉時間設定	0.0~6000.0	0.0	*1
06-26	第10段運轉時間設定	0.0~6000.0	0.0	*1

群組 06 自動運轉功能群組				
代碼	參數名稱	範圍	出廠設定	屬性
06-27	第11段運轉時間設定	0.0~6000.0	0.0	*1
06-28	第12段運轉時間設定	0.0~6000.0	0.0	*1
06-29	第13段運轉時間設定	0.0~6000.0	0.0	*1
06-30	第14段運轉時間設定	0.0~6000.0	0.0	*1
06-31	第15段運轉時間設定	0.0~6000.0	0.0	*1
06-32	第0段運轉方向選擇	0: 停止 1: 正轉 2: 反轉	0	
06-33	第1段運轉方向選擇	0: 停止 1: 正轉 2: 反轉	0	
06-34	第2段運轉方向選擇	0: 停止 1: 正轉 2: 反轉	0	
06-35	第3段運轉方向選擇	0: 停止 1: 正轉 2: 反轉	0	
06-36	第4段運轉方向選擇	0: 停止 1: 正轉 2: 反轉	0	
06-37	第5段運轉方向選擇	0: 停止 1: 正轉 2: 反轉	0	
06-38	第6段運轉方向選擇	0: 停止 1: 正轉 2: 反轉	0	
06-39	第7段運轉方向選擇	0: 停止 1: 正轉 2: 反轉	0	
06-40	第8段運轉方向選擇	0: 停止 1: 正轉 2: 反轉	0	
06-41	第9段運轉方向選擇	0: 停止 1: 正轉 2: 反轉	0	
06-42	第10段運轉方向選擇	0: 停止 1: 正轉 2: 反轉	0	
06-43	第11段運轉方向選擇	0: 停止 1: 正轉 2: 反轉	0	
06-44	第12段運轉方向選擇	0: 停止 1: 正轉 2: 反轉	0	
06-45	第13段運轉方向選擇	0: 停止 1: 正轉 2: 反轉	0	
06-46	第14段運轉方向選擇	0: 停止 1: 正轉 2: 反轉	0	
06-47	第15段運轉方向選擇	0: 停止 1: 正轉 2: 反轉	0	

* : 馬達最大輸出頻率超過 300Hz 時，頻率解析度為 0.1Hz

群組 07 運轉停止功能群組				
代碼	參數名稱	範圍	出廠設定	屬性
07-00	瞬停再啟動選擇	0: 瞬停再啟動無效 1: 瞬停再啟動有效	0	
07-01	自動復歸再啟動時間	0~7200	0	
07-02	自動復歸再啟動次數	0~10	0	
07-03	復歸模式設定	0: 當 RUN 指令存在時·復歸指令無效 1: 復歸指令與 RUN 指令狀態無關	0	
07-04	開機後直接啟動	0: 外部運轉命令有效時·送電後直接啟動 1: 外部運轉命令有效時·送電後不可直接啟動	1	
07-05	開機直接啟動延時間	1.0~300.0	1.0	
07-06	煞車開始頻率	0.0~10.0	1.5	
07-07	直流煞車電流準位	0~100	50	
07-08	停止時直流制動時間	0.00~100.00	0.50	
07-09	停止模式選擇	0: 減速停止 1: 自由運轉停止 2: 全領域直流煞車停止 3: 有計時器的自由運轉停止	0	
07-10	啟動方式選擇	0: 無效 1: 開機後執行一次速度搜尋 2: 速度搜尋啟動	0	
07-13	低壓檢測準位	200V 機種: 100~300	190	
		400V 機種: 250~600	380	
07-15	直流制動模式選擇	0: 電流型制動模式 1: 電壓型制動模式	1	
07-16	啟動時直流制動時間	0.00~100.00	0.00	
07-18	最小遮斷時間	0.1~5.0	KVA	
07-19	轉向尋找電流	0~100	50	
07-20	速度尋找電流	0~100	20	

群組 07 運轉停止功能群組				
代碼	參數名稱	範圍	出廠設定	屬性
07-21	速度尋找積分時間	0.1~10.0	2.0	
07-22	速度尋找延遲時間	0.0~20.0	0.2	
07-23	電壓回復時間	0.1~5.0	2.0	
07-24	雙向速度尋找選擇	0: 無效 1: 有效	1	
07-25	低壓檢測時間	0.00~1.00	0.02	
07-26	SLV 自由運轉停止後啟動方式選擇	0: 速度尋找啟動 1: 正常啟動	0	
07-27	SLV 故障後啟動方式選擇	0: 速度尋找啟動 1: 正常啟動	0	
07-28	遮斷後啟動方式選擇	0: 速度尋找啟動 1: 正常啟動	0	
07-29	直流煞車動作時運轉指令選擇	0: 過程中不允許啟動 1: 過程中允許啟動	0	
07-33	速度搜尋開始頻率選擇	0: 馬達最大輸出頻率	0	
		1: 頻率指令		
07-34	啟動時短路煞車時間	0.00~100.00	0.00	
07-35	停止時短路煞車時間	0.00~100.00	0.50	
07-36	短路煞車電流限制	0.0~200.0	100.0	
07-37	預激磁時間	0.00~10.00	2.00	
07-38	預激磁準位	50~200	100	
07-39	PM 馬達速度搜尋短路煞車時間	0.00~100.00	0.00	
07-40	PM 馬達速度搜尋直流煞車時間	0.00~100.00	0.00	
07-45	STP2 機能選擇	0: 致能 STP2 機能 1: 取消 STP2 機能	0	

* : 馬達最大輸出頻率超過 300Hz 時·頻率解析度為 0.1Hz

群組 08 保護功能群組				
代碼	參數名稱	範圍	出廠設定	屬性
08-00	失速防止功能	xxx0b: 加速時失速防止有效	0000 b	
		xxx1b: 加速時失速防止無效		
		xx0xb: 減速時失速防止有效		
		xx1xb: 減速時失速防止無效		
		x0xxb: 運轉中失速防止有效		
		x1xxb: 運轉中失速防止無效		
		0xxxb: 運轉中失速防止依據第一段減速時間		
		1xxxb: 運轉中失速防止依據第二段減速時間		
08-01	加速失速防止準位	20~200	HD: 150 ND: 120	
08-02	減速失速防止準位	200V: 330V~410V	385 V	
		400V: 660V~820V	770 V	
08-03	運轉中失速防止準位	30~200	HD:1 60 ND:1 20	
08-05	馬達過載(OL1)保護選擇	xxx0b: 馬達過載無效	0001 b	
		xxx1b: 馬達過載有效		
		xx0xb: 馬達過載冷啟動		
		xx1xb: 馬達過載熱啟動		
		x0xxb: 標準馬達		
		x1xxb: 變頻馬達		
		0xxxb: 保留		
		1xxxb: 保留		
08-06	過載(OL1)保護動作啟動方式	0: 過載保護後停止輸出	0	
		1: 過載保護後繼續運轉		
08-07	風扇開關閉選擇	0: 高溫時啟動	1	
		1: 運轉時啟動		

群組 08 保護功能群組				
代碼	參數名稱	範圍	出廠設定	屬性
		2: 永遠啟動		
		3: 停止運轉		
08-08	自動穩壓功能(AVR)	0: 有效	0	
		1: 無效		
08-09	輸入欠相保護選擇	0: 無效	0	
		1: 有效		
08-10	輸出欠相保護選擇	0: 無效	0	
		1: 有效		
08-13	過轉矩檢測選擇	0: 過轉矩偵測無效	0	
		1: 到達設定頻率後開始偵測		
		2: 運轉中即偵測		
08-14	過轉矩動作選擇	0: 檢出後減速停止	0	
		1: 檢出後顯示警告·繼續運轉		
		2: 檢出後自由運轉停止		
08-15	過轉矩檢測準位	0~300	160	
08-16	過轉矩檢測時間	0.0~10.0	0.1	
08-17	火災模式	0: 無效 1: 有效	0	
08-21	加速失速防止限制	1~100	50	
08-22	運轉失速檢測時間	2~100	100	
08-23	接地故障(GF)選擇	0: 無效	0	
		1: 有效		
08-24	外部故障工作選擇	0: 減速停止	0	
		1: 自由運轉停止		
		2: 繼續運轉		
08-25	外部故障檢測選擇	0: 送電後即偵測	0	
		1: 運轉中才偵測		
08-35	馬達過熱故障選擇	0: 無效	0	
		1: 減速停止		
		2: 自由運轉停止		
		3: 持續運轉		
08-36	PTC 輸入濾波時間常數	0.00 ~ 5.00	2.00	
08-38	風扇關閉延遲時間	0~600	60	
08-39	馬達過熱保護延遲時間	1~300	60	
08-40	馬達 2 加速失速防止準位	20~200	HD: 150	
			ND: 120	

群組 08 保護功能群組				
代碼	參數名稱	範圍	出廠設定	屬性
08-41	馬達 2 加速失速防止限制	1~100	50	
08-42	PTC 保護準位	0.1~10.0V	0.7	
08-43	PTC 復歸準位	0.1~10.0V	0.3	
08-44	PTC 警告準位	0.1~10.0V	0.5	
08-46	溫度到達準位	0~254°C	0	
08-47	溫度復歸準位	0~254°C	0	
08-48	火災模式選擇	0: 關閉 1: 致能	0	
08-49	火災模式數位輸入類型	0: 斷電復歸 1: 端子移除復歸	0	
08-50	火災模式數位端子狀態	xxx0b: S6 A 接點 xxx1b: S6 B 接點	0000b	
08-51	火災模式馬達轉速選擇	0: 火災模式速度 (08-52) 1: PID 控制器來源 2: AI2 來源	0	
08-52	火災模式馬達轉速	0.00~100.00	100.00	
08-53	火災模式 PID 偵測準位	0~100	0	
08-54	火災模式 PID 斷線延遲	0.0~10.0	0.0	
08-55	火災模式 PID 斷線動作選擇	0: 當前速度 1: 火災模式速度 2: 馬達 1 最大頻率 (01-02)	0	
08-56	火災模式 AI2 式偵測準位	0~100	0	
08-57	火災模式 AI2 斷線延遲	0.0~10.0	0.0	
08-58	火災模式 AI2 模式斷線動作選擇	0: 當前速度 1: 火災模式速度 2: 馬達 1 最大頻率 (01-02)	0	
08-59	火災模式馬達方向	0: 正轉 1: 反轉	0	
08-60	火災模式密碼	00000~65534	0	

群組 09 通訊功能群組				
代碼	參數名稱	範圍	出廠設定	屬性
09-00	變頻器通訊站別	1~254	1	*3
09-01	通訊模式選擇	0: MODBUS 1: BACNet 3: PUMP 並聯通訊	0	*3
09-02	波特率設定 (bps)	2: 4800 3: 9600 4: 19200 5: 38400	4	*3
09-03	停止位元選擇	0: 1 停止位元 1: 2 停止位元	0	*3
09-04	奇偶位元選擇	0: 無奇偶位 1: 偶位元選擇 2: 奇位元選擇	0	*3
09-05	通訊資料位元選擇	0: 8 位元資料 1: 7 位元資料	0	*3
09-06	通訊異常檢測時間	0.0~25.5	0.0	*3
09-07	故障停止選擇	0: 通訊故障後依減速時間 1 減速停止 1: 通訊故障後自由運轉停止 2: 通訊故障後依減速時間 2 減速停止 3: 通訊故障後繼續運轉	3	*3
09-08	通訊容錯次數	1~20	1	*3
09-09	等待時間	5~65	5	*3
09-10	BACNet 設備站別	1~254	1	*3

*3: 09 群組不受 13-08 初始化影響。

群組 10 PID 功能群組				
代碼	參數名稱	範圍	出廠設定	屬性
10-00	PID 目標值 來源設定	0 : Keypad 旋鈕給定	1	
		1 : 類比 AI1 給定		
		2 : 類比 AI2 給定		
		3 : 通訊給定		
10-01	PID 回授值 來源設定	0 : Keypad 旋鈕給定	2	
		1 : AI1 給定		
		2 : AI2 給定		
		3 : 通訊給定		
10-02	PID 目標值	0.00~100.00	0.00	*1
10-03	PID 控制模式	xxx0b: PID 無效	0000 b	
		xxx1b: PID 有效		
		xx0xb: PID 正特性		
		xx1xb: PID 負特性		
		x0xxb: PID 誤差值 D 控制		
		x1xxb: PID 回授值 D 控制		
		0xxxb: PID 輸出		
		1xxxb: PID 輸出+ 頻率命令		
10-04	反饋比例係數	0.01~10.00	1.00	*1
10-05	比例增益(P)	0.00~10.00	1.00	*1
10-06	積分時間(I)	0.00~100.00	1.00	*1
10-07	微分時間(D)	0.00~10.00	0.00	*1
10-08	微分項一次 延遲時間	1~250	4	*1
10-09	PID 偏壓	-100.0~100.0	0	*1
10-11	PID 回授斷 線檢測	0: 無效	0	
		1: 警告		
		2: 故障		
10-12	PID 回授斷 線檢測準位	0~100	0	
10-13	PID 回授斷 線檢測時間	0.0~25.5	1.0	
10-14	PID 積分限制	0.0~100.0	100.0	*1
10-17	*PID 休眠起 始頻率	0.00~599.00	0.00	
10-18	PID 休眠延 遲時間	0.0~255.5	0.0	
10-19	*PID 喚醒起 始頻率	0.00~599.00	0.00	
10-20	PID 喚醒延 遲時間	0.0~255.5	0.0	

群組 10 PID 功能群組				
代碼	參數名稱	範圍	出廠設定	屬性
10-21		保留		
10-22				
10-23	PID 輸出限制	0.00~100.0	100.0	*1
10-24	PID 輸出增益	0.0~25.0	1.0	
10-25	PID 反向輸出 選擇	0: 不允許反向輸出 1: 允許反向輸出	0	
10-26	PID 目標加/ 減速時間	0.0~25.5	0.0	
10-27	PID 回授顯示 偏壓	-99.99~99.99	0	
10-29	PID 休眠選擇	0: 無效	1	
		1: 有效		
		2: 由 DI 設定		
10-30	PID 目標上限	0.0 ~ 100.0	100.0	
10-31	PID 目標下限	0.0 ~ 100.0	0.0	
10-33	PID 回授最大 值	1 ~ 10000	999	
10-34	PID 小數寬 度	0 ~ 4	1	
10-35	PID 單位	0 : %	0	*7
		1 : FPM		
		2 : CFM		
		3 : SPI		
		4 : GPH		
		5 : GPM		
		6 : IN		
		7 : FT		
		8 : /s		
		9 : /m		
		10 : /h		
		11 : °F		
		12 : inW		
		13 : HP		
		14 : m/s		
		15 : MPM		
		16 : CMM		
		17 : W		
		18 : KW		
		19 : m		
		20 : °C		
		21 : RPM		
		22 : Bar		
		23 : Pa		
24 : kPa				



群組 10 PID 功能群組				
代碼	參數名稱	範圍	出廠設定	屬性
10-39	*PID 斷線輸出頻率設定	00.00~599.00	30.00	
10-40	PID 休眠補償頻率選擇	0: 無效 1: 有效	0	
10-47	比例增益 3(P)	0.00~10.00	1.00	*1
10-48	積分時間 3(I)	0.00~100.00	1.00	*1
10-49	微分時間 3(D)	0.00~10.00	0.00	*1

群組 11 輔助功能群組				
代碼	參數名稱	範圍	出廠設定	屬性
11-00	馬達方向鎖定指令	0: 允許正反轉 1: 只允許正轉 2: 只允許反轉	0	
11-01	載波頻率	1~16KHz	*	
11-02	軟調變選擇	0: 無效 1: 軟調變	0	
11-03	自動降載波選擇	0: 無效 1: 有效	0	
11-04	加速開始 S 曲線時間設定	0.00~2.50	0.20	
11-05	加速結束 S 曲線時間設定	0.00~2.50	0.20	
11-06	減速開始 S 曲線時間設定	0.00~2.50	0.20	
11-07	減速結束 S 曲線時間設定	0.00~2.50	0.20	
11-08	跳躍頻率 1	0.0~599.0	0.0	
11-09	跳躍頻率 2	0.0~599.0	0.0	
11-10	跳躍頻率 3	0.0~599.0	0.0	
11-11	跳躍頻率寬度	0.00~25.5	1.0	
11-12	省能運轉增益 (V/F)	0~100	80	
11-14	再生回避動作水平	230V: 200~400 400V: 400~800	370 740	
11-17	加減速率調整增益	0.1~10.0	1	
11-18	手動省能頻率	0.0~599.0	0.0	
11-28	過壓防止 2 頻率增益	1~200	100	
11-33	DC 電壓濾波上升量	0.1~10.0	0.1	
11-34	DC 電壓濾波下降量	0.1~10.0	5.0	*1

群組 11 輔助功能群組				
代碼	參數名稱	範圍	出廠設定	屬性
11-35	DC 電壓濾波死域準位	0.0~99.0	10.0	*1
11-36	過壓防止頻率增益	0.000~1.000	0.050	*1
11-37	過壓防止頻率限制	*0.00~599.00	5.00	*1
11-38	過壓防止減速開始電壓	200V: 200~400V 400V: 400~800V	300 700	
11-39	過壓防止減速停止電壓	200V: 300~400V 400V: 600~800V	350 750	
11-40	過壓防止選擇	0: 無效 1: 過壓防止模式 1 2: 過壓防止模式 2 3: 過壓防止模式 3	0	
11-47	KEB 減速時間	0.0~25.0	0.0	*1
11-48	KEB 檢測準位	230V: 190~210 400V: 380~420	200V 400V	
11-55	STOP 鍵選擇	0: 運轉指令不由操作器提供時·停止鍵無效 1: 運轉指令不由操作器提供時·停止鍵有效	1	
11-59	防止振盪 1 增益	0.00~2.50	*	
11-60	防止振盪 1 上限	0~100	*	
11-61	防止振盪 1 時間參數	0~100	0	
11-62	防止振盪選擇	0: 無效 1: 模式 1 2: 模式 2	1	
11-63	強磁選擇	0: 無效 1: 有效	1	
11-69	防止振盪 2 增益	0.00~200.00	5.00	
11-70	防止振盪 2 上限	0.01~100.00	5.00	
11-71	防止振盪 2 時間常數	0~30000	100	
11-72	防止振盪 2 增益切換頻率 1	0.01~300.00	30.00	
11-73	防止振盪 2 增益切換頻率 2	0.01~300.00	50.00	

*: 參考附件一

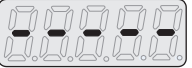
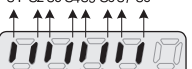
* : 馬達最大輸出頻率超過 300Hz 時·頻率解析度為 0.1Hz

群組 12 監視功能群組				
代碼	參數名稱	範圍	出廠設定	屬性
12-00	顯示畫面選擇 (LED)	00000~88888 由最左位起，依序為按 DSP 鍵後會顯示的畫面 0: 不顯示 1: 輸出電流 2: 輸出電壓 3: DC bus 電壓 4: 溫度* 5: PID 回授 6: AI1 值 7: AI2 值 8: 計數值	00321	*1 *6
12-01	PID 回授顯示模式 (LED)	0:以整數顯示回授值(xxx) 1:以小數點 1 位顯示回授值(xx.x) 2:以小數點 2 位顯示回授值(x.xx)	0	*6
12-02	PID 回授顯示單位設定 (LED)	0:xxxxx (無單位) 1:xxxPb(壓力) 2:xxxFL(流量)	0	*6
12-03	線速度顯示 (LED)	0~60000	1500/ 1800	*6
12-04	線速度顯示模式(LED)	0: 顯示變頻器輸出頻率 1: 以整數顯示線速度(xxxxx) 2: 以小數點 1 位元顯示線速度(xxxx.x) 3: 以小數點 2 位元顯示線速度(xxx.xx) 4: 以小數點 3 位元顯示線速度(xx.xxx)	0	*1 *6
12-05	顯示數位輸入輸出端子狀態 (LED/LCD)	LED 顯示如下 無任何輸入輸出時  有輸入輸出時之對應 S1 S2 S3 S4 S5 S6 S7 S8   R1 R2 DO1 PLC LCD 顯示如下	-	*4

群組 12 監視功能群組				
代碼	參數名稱	範圍	出廠設定	屬性
				
12-11	目前故障時之輸出電流	顯示目前故障時的輸出電流	-	*4
12-12	目前故障時之輸出電壓	顯示目前故障時的輸出電壓	-	*4
12-13	目前故障時之輸出頻率	顯示目前故障時的輸出頻率	-	*4
12-14	目前故障時之直流電壓	顯示目前故障時的直流電壓	-	*4
12-15	目前故障時之頻率命令	顯示目前故障時的頻率命令	-	*4
12-16	頻率命令	LED 進入此參數時，只允許監控頻率命令	-	*4
12-17	輸出頻率	顯示目前的輸出頻率	-	*4
12-18	輸出電流	顯示目前的輸出電流	-	*4
12-19	輸出電壓	顯示目前的輸出電壓	-	*4
12-20	直流電壓 (Vdc)	顯示目前的直流電壓	-	*4
12-21	輸出功率 (kw)	顯示目前的輸出功率	-	*4
12-28	馬達轉矩電流 (Iq)	顯示目前的 q 軸電流		*4
12-29	馬達激磁電流 (Id)	顯示目前的 d 軸電流		*4
12-36	PID 控制輸入	顯示 PID 控制器的誤差輸入(PID 目標值-PID 回授值) (100%對應 01-02 或 01-16 的最大頻率)		*4
12-37	PID 輸出	顯示 PID 控制器的輸出 (100%對應 01-02 或 01-16 的最大頻率)		*4
12-38	PID 設定	顯示 PID 控制器的目標值 (100%對應 01-02 或 01-16 的最大頻率)		*4

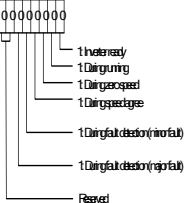
群組 12 監視功能群組				
代碼	參數名稱	範圍	出廠設定	屬性
12-39	PID 回授	顯示 PID 控制器的回授值 (100%對應 01-02 或 01-16 的最大頻率)		*4
12-41	散熱片溫度	顯示散熱片/IGBT 溫度		*4
12-43	變頻器狀態		-	*4
12-74	工作壓力設定	0.01 ~ 25.50	2.00	
12-75	回授壓力值	0.01 ~ 25.50	-	
12-82	馬達負載	顯示目前的馬達負載電流		*4
12-83	E510s 型別	0 : IP20 NFS 1 : IP20 FS 2 : IP66 NFS 3 : IP66 FS	-	*4

群組 13 維護功能群組				
代碼	參數名稱	範圍	出廠設定	屬性
13-00	變頻器馬力數	----	-	*3*4
13-01	軟體版本	0.00-9.99	-	*3*4
13-02	故障紀錄	----	0	*4
13-03	累計工作時間 1	0~23	-	*3*4
13-04	累計工作時間 2	0~65534	-	*3*4
13-05	累計工作時間選擇	0 : 通電時累積時間 1 : 運轉時累積時間	0	*1
13-06	參數鎖定	0 : 13-06 及 05-01 之外的所有參數不可寫 1 : 保留 2 : 所有參數可寫	2	
13-07	參數密碼功能	00000~65534	00000	
13-08	恢復出廠設定	1 : 2 線式初始化 (50Hz) (220V/380V) 2 : 2 線式初始化 (60Hz) (220V/380V)	-	

群組 13 維護功能群組				
代碼	參數名稱	範圍	出廠設定	屬性
		3 : 2 線式初始化 (50Hz) (230V/400V)		
		4 : 2 線式初始化 (60Hz) (230V/460V)		
		5 : 2 線式初始化 (50Hz) (220V/415V)		
		6 : 2 線式初始化 (60Hz) (230V/400V)		
		7 : 2 線式初始化 (50Hz) (220V/440V)		
		8 : 2 線式初始化 (60Hz) (220V/440V)		
		9 : 2 線式初始化 (50Hz) (200V/380V)		
		10 : 2 線式初始化 (60Hz) (200V/380V)		
		1112 : 將 PLC 清除 (RESET)		
13-09	故障履歷清除功能	0: 不清除故障履歷 1: 清除故障履歷	0	
13-10	狀態功能	0~9999		
13-21	前 1 次故障訊息	顯示前 1 次的故障訊息	-	
13-22	前 2 次故障訊息	顯示前 2 次的故障訊息	-	
13-23	前 3 次故障訊息	顯示前 3 次的故障訊息	-	
13-24	前 4 次故障訊息	顯示前 4 次的故障訊息	-	
13-25	前 5 次故障訊息	顯示前 5 次的故障訊息	-	
13-26	前 6 次故障訊息	顯示前 6 次的故障訊息	-	
13-27	前 7 次故障訊息	顯示前 7 次的故障訊息	-	
13-28	前 8 次故障訊息	顯示前 8 次的故障訊息	-	
13-29	前 9 次故障訊息	顯示前 9 次的故障訊息	-	

群組 13 維護功能群組				
代碼	參數名稱	範圍	出廠設定	屬性
13-30	前 10 次故障訊息	顯示前 10 次的故障訊息	-	
13-31	前 11 次故障訊息	顯示前 11 次的故障訊息	-	
13-32	前 12 次故障訊息	顯示前 12 次的故障訊息	-	
13-33	前 13 次故障訊息	顯示前 13 次的故障訊息	-	
13-34	前 14 次故障訊息	顯示前 14 次的故障訊息	-	
13-35	前 15 次故障訊息	顯示前 15 次的故障訊息	-	
13-36	前 16 次故障訊息	顯示前 16 次的故障訊息	-	
13-37	前 17 次故障訊息	顯示前 17 次的故障訊息	-	
13-38	前 18 次故障訊息	顯示前 18 次的故障訊息	-	
13-39	前 19 次故障訊息	顯示前 19 次的故障訊息	-	
13-40	前 20 次故障訊息	顯示前 20 次的故障訊息	-	
13-41	前 21 次故障訊息	顯示前 21 次的故障訊息	-	
13-42	前 22 次故障訊息	顯示前 22 次的故障訊息	-	
13-43	前 23 次故障訊息	顯示前 23 次的故障訊息	-	
13-44	前 24 次故障訊息	顯示前 24 次的故障訊息	-	
13-45	前 25 次故障訊息	顯示前 25 次的故障訊息	-	
13-46	前 26 次故障訊息	顯示前 26 次的故障訊息	-	
13-47	前 27 次故障訊息	顯示前 27 次的故障訊息	-	
13-48	前 28 次故障訊息	顯示前 28 次的故障訊息	-	
13-49	前 29 次故障訊息	顯示前 29 次的故障訊息	-	
13-50	前 30 次故障訊息	顯示前 30 次的故障訊息	-	
13-51	累計工作時間清除	0: 不清除累計工作時間 1: 清除累計工作時間	0	*1

群組 14 PLC 設定群組				
代碼	參數名稱	範圍	出廠設定	屬性
14-00	T1 設定值 1	0~9999	0	
14-01	T1 設定值 2 (模式 7)	0~9999	0	
14-02	T2 設定值 1	0~9999	0	
14-03	T2 設定值 2 (模式 7)	0~9999	0	
14-04	T3 設定值 1	0~9999	0	
14-05	T3 設定值 2 (模式 7)	0~9999	0	
14-06	T4 設定值 1	0~9999	0	
14-07	T4 設定值 2 (模式 7)	0~9999	0	
14-08	T5 設定值 1	0~9999	0	
14-09	T5 設定值 2 (模式 7)	0~9999	0	
14-10	T6 設定值 1	0~9999	0	
14-11	T6 設定值 2 (模式 7)	0~9999	0	
14-12	T7 設定值 1	0~9999	0	
14-13	T7 設定值 2 (模式 7)	0~9999	0	
14-14	T8 設定值 1	0~9999	0	
14-15	T8 設定值 2 (模式 7)	0~9999	0	
14-16	C1 設定值	0~65534	0	
14-17	C2 設定值	0~65534	0	
14-18	C3 設定值	0~65534	0	
14-19	C4 設定值	0~65534	0	
14-20	C5 設定值	0~65534	0	
14-21	C6 設定值	0~65534	0	
14-22	C7 設定值	0~65534	0	
14-23	C8 設定值	0~65534	0	
14-24	AS1 設定值 1	0~65534	0	
14-25	AS1 設定值 2	0~65534	0	
14-26	AS1 設定值 3	0~65534	0	
14-27	AS2 設定值 1	0~65534	0	
14-28	AS2 設定值 2	0~65534	0	
14-29	AS2 設定值 3	0~65534	0	
14-30	AS3 設定值 1	0~65534	0	
14-31	AS3 設定值 2	0~65534	0	
14-32	AS3 設定值 3	0~65534	0	
14-33	AS4 設定值 1	0~65534	0	
14-34	AS4 設定值 2	0~65534	0	
14-35	AS4 設定值 3	0~65534	0	
14-36	MD1 設定值 1	0~65534	1	
14-37	MD1 設定值 2	0~65534	1	

群組 13 維護功能群組				
代碼	參數名稱	範圍	出廠設定	屬性
14-38	MD1 設定值 3	1~65534	1	
14-39	MD2 設定值 1	0~65534	1	
14-40	MD2 設定值 2	0~65534	1	
14-41	MD2 設定值 3	1~65534	1	
14-42	MD3 設定值 1	0~65534	1	
14-43	MD3 設定值 2	0~65534	1	
14-44	MD3 設定值 3	1~65534	1	
14-45	MD4 設定值 1	0~65534	1	
14-46	MD4 設定值 2	0~65534	1	
14-47	MD4 設定值 3	1~65534	1	

群組 15 PLC 監控群組				
代碼	參數名稱	範圍	出廠設定	屬性
15-15	T8 目前值 2 (模式 7)	0~9999	0	*4
15-16	C1 目前值	0~65534	0	*4
15-17	C2 目前值	0~65534	0	*4
15-18	C3 目前值	0~65534	0	*4
15-19	C4 目前值	0~65534	0	*4
15-20	C5 目前值	0~65534	0	*4
15-21	C6 目前值	0~65534	0	*4
15-22	C7 目前值	0~65534	0	*4
15-23	C8 目前值	0~65534	0	*4
15-24	AS1 計算結果	0~65534	0	*4
15-25	AS2 計算結果	0~65534	0	*4
15-26	AS3 計算結果	0~65534	0	*4
15-27	AS4 計算結果	0~65534	0	*4
15-28	MD1 計算結果	0~65534	0	*4
15-29	MD2 計算結果	0~65534	0	*4
15-30	MD3 計算結果	0~65534	0	*4
15-31	MD4 計算結果	0~65534	0	*4
15-32	TD 目前值	0~65534	0	*4

群組 15 PLC 監控群組				
代碼	參數名稱	範圍	出廠設定	屬性
15-00	T1 目前值 1	0~9999	0	*4
15-01	T1 目前值 2 (模式 7)	0~9999	0	*4
15-02	T2 目前值 1	0~9999	0	*4
15-03	T2 目前值 2 (模式 7)	0~9999	0	*4
15-04	T3 目前值 1	0~9999	0	*4
15-05	T3 目前值 2 (模式 7)	0~9999	0	*4
15-06	T4 目前值 1	0~9999	0	*4
15-07	T4 目前值 2 (模式 7)	0~9999	0	*4
15-08	T5 目前值 1	0~9999	0	*4
15-09	T5 目前值 2 (模式 7)	0~9999	0	*4
15-10	T6 目前值 1	0~9999	0	*4
15-11	T6 目前值 2 (模式 7)	0~9999	0	*4
15-12	T7 目前值 1	0~9999	0	*4
15-13	T7 目前值 2 (模式 7)	0~9999	0	*4
15-14	T8 目前值 1	0~9999	0	*4

群組 16 LCD 功能群組				
代碼	參數名稱	範圍	出廠設定	屬性
16-00	主螢幕監看	5~83 使用 LCD 操作器時·第一行顯示的監控項目 (初始值為頻率指令)	16	*1*7
16-01	子螢幕監看 1	5~83 使用 LCD 操作器時·第二行顯示的監控項目 (初始值為輸出頻率)	17	*1*7
16-02	子螢幕監看 2	5~83 使用 LCD 操作器時·第三行顯示的監控項目 (初始值為輸出電流)	18	*1*7
16-03	顯示單位選擇	0~39999 決定頻率指令顯示的方式及單位 0: 頻率顯示單位為 0.01Hz	0	*7

群組 16 LCD 功能群組				
代碼	參數名稱	範圍	出廠設定	屬性
		1：頻率顯示單位為0.01%		
		2：頻率顯示單位為RPM		
		3~39：保留		
		40~9999：使用者指定格式·輸入 0XXXX 表示100%時的顯示為XXXX		
		10001~19999：使用者指定格式·輸入 1XXXX 表示100%時的顯示為XXX.X		
		20001~29999：使用者指定格式·輸入 2XXXX 表示100%時的顯示為XX.XX		
16-04	工程單位選擇	0：不使用工程單位	0	*7
		1：FPM		
		2：CFM		
		3：PSI		
		4：GPH		
		5：GPM		
		6：IN		
		7：FT		
		8：/s		
		9：/m		
		10：/h		
		11：°F		
		12：inW		
		13：HP		
		14：m/s		
		15：MPM		
		16：CMM		
		17：W		
		18：KW		
		19：m		
		20：°C		
		21：RPM		
22：Bar				

群組 16 LCD 功能群組				
代碼	參數名稱	範圍	出廠設定	屬性
		23：Pa		
		24：kPa		
16-05	LCD 背光	0~7	5	*1*7
16-07	複製功能選擇	0：不進行參數複製	0	*7
		1：讀取變頻器參數·存至操作器		
		2：將操作器參數寫入變頻器		
16-08	允許讀取選擇	0：不允許讀取變頻器參數·存至操作器	0	*7
		1：允許讀取變頻器參數·存至操作器		
16-09	操作器斷線選擇	0：LCD 操作器斷線繼續運轉	0	*1*7
		1：LCD 操作器斷線顯示故障		

群組 17 自動調校功能群組				
代碼	參數名稱	範圍	出廠設定	屬性
17-00	*自動調校模式選擇	0：旋轉自動調校	VF:2 SLV:6	
		1：靜止自動調校		
		2：定子電阻量測		
		3：保留		
		4：迴路調校		
		5：旋轉自動調校整合(選項：4+2+0)		
17-01	馬達額定輸出功率	0.00~600.00	KVA	
		6：靜止自動調校整合(選項：4+2+1)		
17-02	馬達額定電流	0.1~1200.0	KVA	
17-03	馬達額定電壓	200V: 50.0~240.0	220	
		400V: 100.0~480.0		
17-04	馬達額定頻率	4.8~599.0	60.0	
17-05	馬達額定轉速	0~24000	KVA	

群組 17 自動調校功能群組				
代碼	參數名稱	範圍	出廠設定	屬性
17-06	馬達極數	2~16(偶數)	4	
17-08	馬達無載電壓	200V: 50~240 400V:100~480	KVA	
17-09	馬達激磁電流	0.01~600.00	KVA	
17-10	自動調校啟動	0: 無效 1: 有效	0	
17-11	自動調校錯誤履歷	0: 無誤 1: 馬達資料錯誤 2: 定子電阻調校錯誤 3: 漏感調校錯誤 4: 轉子電阻調校錯誤 5: 互感調校錯誤 6: DT 錯誤 7: 編碼器錯誤 8: 馬達加速錯誤 9: 警告	0	*4
17-12	馬達漏感比例	0.1~15.0	KVA	
17-13	馬達滑差頻率	0.10~20.00	KVA	
17-14	旋轉調校型式選擇	0: VF 型旋轉自動調校 1: 向量型旋轉自動調校	0	

KVA:該參數會隨著不同變頻器的容量大小而不同。

*在使用馬達自動調校前，建議先選定 00-27

HD/ND 模式選擇。

註:向量模式 17-00 出廠值為 6 靜止自動調校整合(選項:4+2+1)·若馬達無掛載可以進行旋轉調校時，建議進行 5：旋轉自動調校整合(選項:4+2+0)

群組 18 滑差補償功能群組				
代碼	參數名稱	範圍	出廠設定	屬性
18-00	低速滑差補償增益	0.00~2.50	VF:0.00 SLV:***	*1
18-01	高速滑差補償增益	-1.00~1.00	0.0	*1
18-02	滑差補償限制	0~250	200	
18-03	滑差補償濾波時間	0.0~10.0	1.0	
18-04	回昇滑差補償選擇	0: 無效 1: 有效	0	
18-05	FOC 延遲時間	1~1000	100	

群組 18 滑差補償功能群組				
代碼	參數名稱	範圍	出廠設定	屬性
18-06	FOC 增益	0.00~2.00	0.1	

***：請參閱附件一說明

群組 20 速度控制功能群組				
代碼	參數名稱	範圍	出廠設定	屬性
20-00	ASR 增益 1	0.00~250.00	-	*1
20-01	ASR 積分時間 1	0.001~10.000	-	*1
20-02	ASR 增益 2	0.00~250.00	-	*1
20-03	ASR 積分時間 2	0.001~10.000	-	*1
20-04	ASR 積分時間限制	0~300	200	
20-07	加減速 P/PI 選擇	0: PI 速度控制只在定速時有效；加減速時只使用 P 控制 1: PI 速度控制在定速及加減速都有效	0	
20-08	ASR 延遲時間	0.000~0.500	0.004	
20-09	速度觀測增益 1	0.00~2.55	0.61	*1
20-10	速度觀測積分時間 1	0.01~10.00	0.05	*1
20-11	速度觀測增益 2	0.00~2.55	0.61	*1
20-12	速度觀測積分時間 2	0.01~10.00	0.06	*1
20-13	速度回授低通濾波常數 1	1~1000	4	
20-14	速度回授低通濾波常數 2	1~1000	30	
20-15	ASR 增益改變頻率 1	0.0~599.0	4.0	
20-16	ASR 增益改變頻率 2	0.0~599.0	8.0	
20-17	低速轉矩補償增益	0.00~2.50	1.00	*1
20-18	高速轉矩補償增益	-10~10	0	*1
20-33	定速偵測準位	0.1~5.0	1.0	*1
20-34	降轉補償增益	0~25600	0	*1

群組 20 速度控制功能群組				
代碼	參數名稱	範圍	出廠設定	屬性
20-35	降轉補償時間	0~30000	100	*1

群組 21 轉矩限制功能群組				
代碼	參數名稱	範圍	出廠設定	屬性
21-05	正轉矩限制	0~300	150	*1
21-06	負轉矩限制	0~300	150	*1
21-07	正轉回昇轉矩限制	0~300	150	*1
21-08	反轉回昇轉矩限制	0~300	150	*1

群組 22 PM 馬達群組				
代碼	參數名稱	範圍	出廠設定	屬性
22-00	PM 馬達額定功率	0.00~600.00	KVA	
22-02	PM 馬達額定電流	變頻器額定電流的 25%~200%	KVA	
22-03	PM 馬達極數	2~96	8	
22-04	PM 馬達額定轉速	6~60000	1500	
22-05	PM 馬達最大轉速	6~60000	1500	
22-06	PM 馬達額定頻率	4.8~599.0	75.0	
22-07	PM 馬達類型選擇	0: SPM 1: IPM	0	
22-10	PM SLV 啟動電流	20~200%馬達額定電流	50	
22-11	I/F 模式啟動頻率切換點	1.0 ~ 20.0	10.0	
22-14	PM 馬達電樞電阻	0.001 ~ 30.000	1.000	
22-15	PM 馬達 D 軸電感	0.01 ~ 300.00	10.00	
22-16	PM 馬達 Q 軸電感	0.01 ~ 300.00	10.00	
22-18	弱磁限制	0~120	90	
22-21	PM 馬達調校	0: 不進行 PM 馬達調適 1: 參數自動調測方法 1 2: 參數自動調測方法 2 3: 旋轉自動調測	0	

群組 22 PM 馬達群組				
代碼	參數名稱	範圍	出廠設定	屬性
22-22	PM 馬達調校故障履歷	0: 無錯誤 1: 靜止磁極對位失敗 2~4: 保留 5: 迴路調整逾時 6: 保留 7: 其他馬達調校錯誤 8: 保留 9: 迴路調整時電流異常 10: 保留 11: 定子電阻量測逾時	0	*4
22-23	PMSLV 開迴路加速時間	0.1~10.0	1.0	
22-25	初始磁極偵測方式選擇	0: 使用停止前的角度 1: 偵測方式選擇 1 2: 偵測方式選擇 2 3: 偵測方式選擇 3	2	
22-26	高速控比致能 (適用 PMSLV)	0: 低速開迴控制 1: 低速高頻控制 2: 全閉迴控制	0	
22-27	方法 2 電壓命令	5~120 (22-25=2 或 22-26=1 有效)	50	
22-28	方法 2 除頻比例	0~8 (22-25=2 或 22-26=1 有效)	2	
22-29	弱磁電壓命令限制	80~110 (與 22-18 相關)	100	
22-32	MTPA 選擇	0: 無效 1: 方式 1 2: 方式 2 3: 方式 3	0	
22-33	MTPA 增益	0~400%	200	
22-34	IPM 估測器增益	1~300.0	180	
22-38	開閉環切換點頻率寬度(%)	1.0~40.0	5.0	
22-39	預先直流注入時間	0~20.00	0.10	
22-40	高頻找角時間	0.01~1.00	0.01	
22-41	PM 停止方式	0: 減速或停機低於 22-11 直接剎車	0	

群組 22 PM 馬達群組				
代碼	參數名稱	範圍	出廠設定	屬性
		1: 減速或停機低於 22-11 回開迴路		
22-42	全閉迴控制增益 Ka	64~8192	100	
22-43	全閉迴控制增益 Kb	64~8192	2000	
22-44	全閉迴控制增益速度低通率波	1~256	4	
22-45	全閉迴控制磁通	0.01~10.00	0.70	

群組 23 PUMP 與 HVAC 群組				
代碼	參數名稱	範圍	出廠設定	屬性
23-00	機能選擇	0: 無效 1: 泵浦選擇 2: HVAC 選擇 3: 壓縮機選擇 (V1.03 加入)	0	
23-01	單多泵浦及主副機設定	0: 單 Pump 1: 主機 2: 副機 1 3: 副機 2 4: 副機 3	0	
23-02	工作壓力設定	0.10 ~ 650.00	2.00	
23-03	壓力傳送器最大壓力	0.10 ~ 650.00	10.00	
23-04	泵浦壓力命令來源	0: 由 23-02 參數設定 1: 由 AI 設定	0	
23-05	顯示方式選擇	0: 顯示目標壓力及回授壓力(若配合 LED 操作器, 23-03 需小於 9.9PSI) 1: 僅顯示目標壓力 2: 僅顯示回授壓力	0	
23-06	比例增益(P)	0.00~10.00	3.00	
23-07	積分時間(I)	0.0~100.0	0.5	
23-08	微分時間(D)	0.00~10.00	0.00	
23-09	恆壓誤差範圍	0.01 ~ 650.00	0.5	
23-10	恆壓休眠頻率	0.00 ~ 599.00	30.00	
23-11	恆壓休眠時間	0.0 ~ 255.5	0.0	
23-12	最大壓力限制	0.00 ~ 650.00	5	
23-13	高壓警告時間	0.0 ~ 600.0	10.0	
23-14	高壓停機時間	0.0 ~ 600.0	20.0	

群組 23 PUMP 與 HVAC 群組				
代碼	參數名稱	範圍	出廠設定	屬性
23-15	最小壓力限制	23-20=0 : 0.00 ~ 650.00 23-20=1 : 0~100	5	
23-16	低壓警告時間	0.0 ~ 600.0	0.0	
23-17	低壓故障停機時間	0.0 ~ 600.0	0.0	
23-18	失壓檢測時間	0.0 ~ 600.0	0.0	
23-19	失壓檢測比例	0 ~ 100	0	
23-22	副機跳脫頻率	0.00 ~ 599.00	45.00	
23-23	用水檢測方向	0: 向上檢測 1: 向下檢測	1	
23-24	用水檢測壓力範圍	0.00 ~ 65.00	0.1	
23-25	用水檢測週期	0.0 ~ 200.0	30.0	
23-26	用水檢測加速時間	0.1 ~ 6000.0	KVA	
23-27	用水檢測減速時間	0.1 ~ 6000.0	KVA	
23-28	強制運轉頻率	0.00 ~ 599.00	0.00	
23-29	多泵浦併聯交替時間	0 ~ 240	3	
23-30	多泵浦併聯輔助打水偵測時間	0.0 ~ 30.0	5.0	
23-31	多泵浦併聯同步選擇	0: 關閉 1: 壓力設定及 Run/Stop 同步 2: 壓力設定同步 3: Run/Stop 同步	1	
23-34	恆壓誤差範圍 2	0.01 ~ 650.00	0.5	
23-35	多台併聯交換選擇	0: 不進行功能 1: 計時器交替選擇 2: 休眠停止交替選擇 3: 計時器與休眠停止交替選擇 4: 多台併聯測試模式	1	
23-37	漏水檢測時間	0.0~100.0	0.0	
23-38	漏水檢測再啟動壓力變化量	0.01 ~ 65.00	0.1	
23-39	漏水檢測再啟動誤差範圍	0.01 ~ 650.00	0.5	
23-71	壓力設定最大值	0.10~650.00	10.00	
23-72	併聯交替時間 1: 分鐘	0: 小時	0	
23-73	副機喚醒選擇	0: 無效	0	

群組 23 PUMP 與 HVAC 群組				
代碼	參數名稱	範圍	出廠設定	屬性
		1: 有效		
23-74	高壓動作設定	0: 無效 1: 只有高壓警告 2: 高壓警告錯誤都有效	2	
23-75	低壓動作設定	0: 無效 1: 只有低壓警告 2: 低壓警告錯誤都有效	0	
23-78	失壓檢測動作選擇	0: 無效 1: 失壓警告 2: 失壓錯誤	0	













第 4 章 異常診斷及保養

4.1 故障顯示及對策

4.1.1 手動復歸與自動復歸

表 1 錯誤訊息與改正行動

LED 顯示	改正行動
OC 過電流	<ul style="list-style-type: none"> ● 延長加速 / 減速時間。 ● 檢查負載接線。 ● 移除馬達並嘗試運轉變頻器。
	
OCA 過電流	<ul style="list-style-type: none"> ● 設定較長的加速時間 ● 更換容量相當的變頻器 ● 檢修馬達 ● 檢查配線 ● 更換 IGBT 模組
	
OCC 過電流	<ul style="list-style-type: none"> ● 加大變頻器容量 ● 電源輸入側加裝電抗器
	
OCD 過電流	設定較長的減速時間
	
GF 接地故障	檢查馬達接線及接線阻抗。
	
OV 過壓	<ul style="list-style-type: none"> ● 延長減速時間。 ● 檢查輸入電路和降低輸入電壓符合規範要求。 ● 移除功率因數校正電容。
	
LV 電壓過低	<ul style="list-style-type: none"> ● 檢查輸入電路和電源電壓。 ● 延長加速時間。
	
IPL 輸入欠相	<ul style="list-style-type: none"> ● 確認主回路接線是否正確。

LED 顯示	改正行動
	<ul style="list-style-type: none"> ● 檢查端子螺絲是否鬆動。 ● 確認電源電壓採取穩定電壓的對策，或將輸入欠相檢出關閉。 ● 更換電路板或變頻器。
OPL 輸出欠相	<ul style="list-style-type: none"> ● 檢查馬達的接線。 ● 檢查馬達和變頻器容量。
	
OH1 散熱座過熱	<ul style="list-style-type: none"> ● 檢查變頻器環境周溫。 ● 檢查風扇或散熱槽之塵埃和污垢。 ● 檢查載波頻率之設定。
	
OH4 馬達過熱	<ul style="list-style-type: none"> ● 檢查馬達環境周溫。 ● 檢查 MT 與 GND 端接線是否正確。
	
OL1 馬達過載	<ul style="list-style-type: none"> ● 檢查 V/F 模式。 ● 檢查馬達額定電流。 ● 檢查負載大小和運轉週期時間。
	
OL2 變頻器過載	<ul style="list-style-type: none"> ● 檢查 V/F 模式。 ● 替換更高容量的變頻器。 ● 檢查負載大小和運轉週期時間。
	
OT 過轉矩偵測	<ul style="list-style-type: none"> ● 檢查應用程序或操作狀態。 ● 檢查 08-15 及 08-16 是否為適當值。
	
CE 通訊錯誤	檢查所有連接和驗證所有用戶端軟體架構。
	
FB PID 回授斷線	<ul style="list-style-type: none"> ● 檢查設立的 PID 回授方式是否正確。 ● 確保正確安裝及 PID 回授信號的工作正常。
	
PO 電壓關閉	檢查變頻器控制板上 SF1 與 SG 是否短路。
	
STO1 安全開關 1	檢查變頻器控制板上 SF1 與 SG 是否短路。
	
PO2 電壓開關	<ul style="list-style-type: none"> ● 檢查變頻器控制板上 SF2 與 SG 是否短路。
	
STO2 安全開關 2	檢查變頻器控制板上 SF2 與 SG 是否短路。
	

LED 顯示	改正行動
PO3 電壓開關 PO3	<ul style="list-style-type: none"> 建議更換電源板 請聯繫客服人員進行檢修
STO3 安全開關 3 STO3	<ul style="list-style-type: none"> 建議更換電源板。 請聯繫客服人員檢修。
EF0 外部故障 0 EF0	<ul style="list-style-type: none"> 檢查外部故障原因。 復歸通訊位置 0x2501 的 bit 2
EF1 外部故障(S1) EF1	<ul style="list-style-type: none"> 檢查外部原因故障。 復歸多功能數位輸入的外部故障。
EF2 外部故障(S2) EF2	
EF3 外部故障(S3) EF3	
EF4 外部故障(S4) EF4	
EF5 外部故障(S5) EF5	
EF6 外部故障(S6) EF6	
CF07 馬達控制故障 CF07	
CF08 馬達控制故障 CF08	
CF00 操作器通訊異常 CF00	

LED 顯示	改正行動
CF01 操作器通訊異常 2 CF01	<ul style="list-style-type: none"> 數位操作器之連接器拔起再插入 更換控制基板
OPR 斷線 OPR	檢查數位操作器是否斷線或被移除
FBLSS PID 回授訊號遺失 FBLSS	<ul style="list-style-type: none"> 檢查設立的 23-19 施壓比例是否正確。 確保正確安裝及 PID 回授信號的工作正常。
SC 短路 SC	確認負載接線
run 馬達 1/馬達 2 切換 run	修正順序控制，以便在停止時進行馬達切換。
LPBFT 低壓故障 LPBFT	<ul style="list-style-type: none"> 檢查回授訊號是否正確且有接上。 確認回授壓力是否低於最小壓力限制值(參數 23-15)。
OPBFT 高壓故障 OPBFT	<ul style="list-style-type: none"> 檢查回授訊號是否正確。 確認回授壓力是否高於最大壓力限制值(參數 23-12)。
PF 保護錯誤 PF	移除數位輸入端子/通訊運轉命令
TOL 外部過載 TOL	<ul style="list-style-type: none"> 檢查外部原因過載。 復歸多功能數位輸入的外部過載。
FB(閃爍) PID 回授斷線 FB	<ul style="list-style-type: none"> 檢查設立的 PID 回授方式是否正確。 確保正確安裝及 PID 回授信號的工作正常。

表 2 警告/自診斷和糾正措施

LED 顯示	改正行動
OV (閃爍) 過電壓 OV	檢查輸入電源之電壓。
OV	

LED 顯示	改正行動
UV (閃爍) 低電壓	<ul style="list-style-type: none"> ● 檢查輸入電源電壓。 ● 檢查輸入電路。 ● 檢查主回路 MC。
OH1 散熱座過熱	<ul style="list-style-type: none"> ● 檢查變頻器環境周溫。 ● 檢查風扇或散熱槽之塵埃和污垢。 ● 檢查載波頻率之設定。
OH3 馬達過熱警告	<ul style="list-style-type: none"> ● 檢查馬達環境周圍溫度。 ● 檢查 MT 與 GND 端接線是否正確。
OT (閃爍) 過轉矩偵測	<ul style="list-style-type: none"> ● 檢查應用或機器運轉狀態。 ● 檢查 08-15 和 08-16 設定值。
OL1 馬達過載	<ul style="list-style-type: none"> ● 檢查 V/F 模式。 ● 檢查馬達額定電流。 ● 檢查負載大小和運轉週期時間。
OL2 變頻器過載	<ul style="list-style-type: none"> ● 檢查 V/F 模式。 ● 替換至更高容量的變頻器 ● 檢查負載大小和運轉週期時間。
CE(閃爍) 通訊錯誤	檢查所有連接並驗證所有用戶端軟體設定。
Retry(閃爍) 重試	自動復歸再啟動時間過後會消失。
ES (閃爍) 外部緊急停止	<ul style="list-style-type: none"> ● 移除外部緊急停止的原因。 ● 運轉命令關閉,並且復歸多功能數位輸入的外部緊急停止命令。
bb1(閃爍) 外部遮斷	移除外部遮斷的原因。
bb2(閃爍) 外部遮斷	
bb3(閃爍)	

LED 顯示	改正行動
外部遮斷	
bb4(閃爍) 外部遮斷	
bb5(閃爍) 外部遮斷	
bb6(閃爍) 外部遮斷	
EF9 (閃爍) 正反轉錯誤	檢查外部程序邏輯。
SE01 設定範圍錯誤	檢查參數設置。
SE02 數位輸入 端子錯誤	檢查參數設置。
SE03 V/f 曲線錯誤	確認 V/F 參數設定。
SE05 PID 選擇錯誤	1.檢查參數 10-00,10-01 設定值 2.檢查參數 10-33/34, 23-05 的設定值。
HPErr 機種選擇錯誤	檢查變頻器容量設置 (13-00)符合硬體電壓等級。
CLB 電流保護準位 B	檢查負載大小和運轉週期

LED 顯示	改正行動
	時間。
EF1 (閃爍) 外部故障(S1)	<ul style="list-style-type: none"> ● 檢查外部故障的原因。 ● 復歸多功能數位輸入的外部故障。
EF2 (閃爍) 外部故障(S2)	
EF3 (閃爍) 外部故障(S3)	
EF4 (閃爍) 外部故障(S4)	
EF5 (閃爍) 外部故障(S5)	
EF6 (閃爍) 外部故障(S6)	檢查外部程序邏輯。
EF9 (閃爍) 正反轉錯誤	
SE09 PI 設定錯誤	檢查變頻器 PI 選項 (03-30) 選擇與 PID 來源 (10-00 及 10-01)。
FB(閃爍) PID 回授斷線	<ul style="list-style-type: none"> ● 檢查設立的 PID 回授方式是否正確。 ● 確保正確安裝及 PID 回授信號的工作正常。
FIRE 強制運轉模式	確認設備周圍是否發生火災，如果是誤觸發可斷電重新清除。
參數設定錯誤	請參照手冊設定或者代表

LED 顯示	改正行動
	此項選擇無效
直接啟動警告	檢查數位端子運轉端先斷開，等待 07-05 時間過後，再重新接上數位端子運轉。
外控停止警告	移除外部運轉命令。
EEPROM 儲存錯誤	<ul style="list-style-type: none"> ● 重新斷送電，若再次出現警告，則更換電路板。 ● 請連絡東元。
控制板錯誤	控制板與程式不符合，請更換控制板。
運轉方向運轉錯誤	取消外控端子按壓之相反方向運轉命令
參數鎖定	在參數 13-07 輸入正確密碼
密碼設定錯誤	使用密碼鎖功能時，第二次輸入的密碼與第一次輸入的密碼相同
重複運轉命令	取消外控端子按壓之反方向運轉命令
零速停止警告	設定頻率命令
操作器拷貝錯誤 RDE*	檢查變頻器與操作器連結是否正常
操作器寫入錯誤 WRE*	檢查變頻器之版本/控制模式/機種別
操作器比對錯誤 VRYE*	檢查變頻器與操作器連結是否正常
操作器讀取禁止 RDP*	允許讀取選擇(16-08)設定為允許讀取變頻器參數存至操作器

* RDE、WRE、VRYE、RDP 為 LCD 介面才會顯示的警告訊號。

● Main Circuit Terminal Wiring

UL approval requires crimp terminals when wiring the drive's main circuit terminals. Use crimping tools as specified by the crimp terminal manufacturer. Teco recommends crimp terminals made by NICHIFU for the insulation cap. The table below matches drives models with crimp terminals and insulation caps. Orders can be placed with a Teco representative or directly with the Teco sales department.

Closed-Loop Crimp Terminal Size

Drive Model 11-201(series)	Wire Gauge mm2 (AWG)		Terminal Screws	Crimp Terminal Model No.	Tool Machine No.	Insulation Model No.
	R/L1, S/L2, T/L3	U/T1, V/T2, W, T3				
11-201-20-2P5-00	2 (14)		M3.5	R2-3.5	Nichifu NH 1/9	TIC 2
11-201-20-201-00	2 (14)		M3.5	R2-3.5	Nichifu NH 1/9	TIC 2
11-201-20-202-00	3.5 (12)		M4	R5.5-4	Nichifu NH 1/9	TIC 3.5
11-201-20-203-00	5.5 (10)		M4	R5.5-4	Nichifu NH 1/9	TIC 5.5
11-201-23-202-00	3.5 (12)		M4	R5.5-4	Nichifu NH 1/9	TIC 3.5
11-201-23-205-00	5.5 (10)		M4	R5.5-4	Nichifu NH 1/9	TIC 5.5
11-201-23-208-00	8 (8)		M4	R8-4	Nichifu NOP 60	TIC 8
11-201-23-210-00	8 (8)		M4	R8-4	Nichifu NOP 60	TIC 8
11-201-23-215-00	22 (4)		M6	R22-6	Nichifu NOP 60/150H	TIC 22
11-201-23-220-00	22 (4)		M6	R22-6	Nichifu NOP 60/150H	TIC 22
11-201-23-225-00	22 (4)		M6	R22-6	Nichifu NOP 60/150H	TIC 22
11-201-23-230-00	60 (1/0)		M8	R60-8	Nichifu NH 1/9	TIC 60
11-201-23-240-00	60 (1/0)		M8	R60-8	Nichifu NH 1/9	TIC 60
11-201-43-401-00	2 (14)		M3.5	R2-3.5	Nichifu NH 1/9	TIC 2
11-201-43-402-00	2 (14)		M3.5	R2-3.5	Nichifu NH 1/9	TIC 2
11-201-43-403-00	2 (14)		M4	R2-4	Nichifu NH 1/9	TIC 2
11-201-43-405-00	2 (14)		M4	R2-4	Nichifu NH 1/9	TIC 2
11-201-43-408-00	8 (8)		M4	R8-4	Nichifu NOP 60	TIC 8
11-201-43-410-00	8 (8)		M4	R8-4	Nichifu NOP 60	TIC 8
11-201-43-415-00	8 (8)		M4	R8-4	Nichifu NOP 60	TIC 8
11-201-43-420-00	8 (8)		M4	R8-4	Nichifu NOP 60	TIC 8
11-201-43-425-00	8 (8)		M4	R8-4	Nichifu NOP 60	TIC 8
11-201-43-430-00	14 (6)		M6	R14-6	Nichifu NOP 60/150H	TIC 14
11-201-43-440-00	38 (2)		M8	R38-8	Nichifu NOP 60/150H	TIC 38
11-201-43-450-00	38 (2)		M8	R38-8	Nichifu NOP 60/150H	TIC 38
11-201-43-460-00	38 (2)		M8	R38-8	Nichifu NOP 60/150H	TIC 38
11-201-43-475-00	38 (2)		M8	R38-8	Nichifu NOP 60/150H	TIC 38

Closed-Loop Crimp Terminal Size

Drive Model 11-301(series)	Wire Gauge mm2 (AWG)		Terminal Screws	Crimp Terminal Model No.	Tool Machine No.	Insulation Model No.
	R/L1, S/L2, T/L3	U/T1, V/T2, W,T3				
11-301-21-2P5-30	2 (14)		M3.5	R2-3.5	Nichifu NH 1/9	TIC 2
11-301-21-201-30	2 (14)		M3.5	R2-3.5	Nichifu NH 1/9	TIC 2
11-301-21-202-30	3.5 (12)		M4	R5.5-4	Nichifu NH 1/9	TIC 3.5
11-301-21-203-30	5.5 (10)		M4	R5.5-4	Nichifu NH 1/9	TIC 5.5
11-301-43-401-30	2 (14)		M3.5	R2-3.5	Nichifu NH 1/9	TIC 2
11-301-43-402-30	2 (14)		M3.5	R2-3.5	Nichifu NH 1/9	TIC 2
11-301-43-403-30	2 (14)		M4	R2-4	Nichifu NH 1/9	TIC 2
11-301-43-405-30	2 (14)		M4	R2-4	Nichifu NH 1/9	TIC 2
11-301-43-408-30	8 (8)		M4	R8-4	Nichifu NOP 60	TIC 8
11-301-43-410-30	8 (8)		M4	R8-4	Nichifu NOP 60	TIC 8
11-301-43-415-30	8 (8)		M4	R8-4	Nichifu NOP 60	TIC 8
11-301-43-420-30	8 (8)		M4	R8-4	Nichifu NOP 60	TIC 8
11-301-43-425-30	8 (8)		M4	R8-4	Nichifu NOP 60	TIC 8
11-301-43-430-30	14 (6)		M6	R14-6	Nichifu NOP 60/150H	TIC 14
11-301-43-440-30	38 (2)		M8	R38-8	Nichifu NOP 60/150H	TIC 38
11-301-43-450-30	38 (2)		M8	R38-8	Nichifu NOP 60/150H	TIC 38
11-301-43-460-30	38 (2)		M8	R38-8	Nichifu NOP 60/150H	TIC 38
11-301-43-475-30	38 (2)		M8	R38-8	Nichifu NOP 60/150H	TIC 38

- **Motor Over-temperature Protection**

Motor over-temperature protection shall be provided in the end use application.

- **Field Wiring Terminals**

All input and output field wiring terminals not located within the motor circuit shall be marked to indicate the proper connections that are to be made to each terminal and indicate that copper conductors, rated 75°C are to be used.

- **Drive Short-Circuit Rating**



This drive has undergone the UL short-circuit test, which certifies that during a short circuit in the power supply the current flow will not rise above value. Please see electrical ratings for maximum voltage and table below for current. The MCCB and breaker protection and fuse ratings (refer to the preceding table) shall be equal to or greater than the short-circuit tolerance of the power supply being used.

Horse Power (Hp)	Current (A)	Voltage (V)
1 - 50	5,000	240 / 480
51 - 200	10,000	240 / 480

Recommended Input Fuse Selection

Drive Model 11-201/11-301	Fuse Type	
	Manufacturer: Bussmann / Ferraz Shawmut	
	Model	Fuse Ampere Rating
11-201-20-2P5-00	Bussmann 20CT	690V / 20A
11-201-20-201-00	Bussmann 20CT	690V / 20A
11-201-20-202-00	Bussmann 32FE	690V / 32A
11-201-20-203-00	Bussmann 50FE	690V / 50A
11-201-23-202-00	Bussmann 20CT	690V / 20A
11-201-23-205-00	Bussmann50FE	690V / 50A
11-201-23-208-00	Bussmann 63FE	690V / 63A
11-201-23-210-00	Ferraz Shawmut A50QS100-4	500V / 100A
11-201-23-215-00	Ferraz Shawmut A50QS150-4	500V / 150A
11-201-23-220-00	Ferraz Shawmut A50QS150-4	500V / 150A
11-201-23-225-00	Ferraz Shawmut A50QS200-4	500V / 200A
11-201-23-230-00	Ferraz Shawmut A50QS250-4	500V / 250A
11-201-23-240-00	Ferraz Shawmut A50QS300-4	500V / 300A
11-201-43-401-00	Bussmann 10CT	690V / 10A
11-201-43-402-00	Bussmann 16CT	690V / 16A
11-201-43-403-00	Bussmann 16CT	690V / 16A
11-201-43-405-00	Bussmann 25ET	690V / 25A
11-201-43-408-00	Bussmann 40FE	690V / 40A
11-201-43-410-00	Bussmann 50FE	690V / 50A
11-201-43-415-00	Bussmann 63FE	690V / 63A
11-201-43-420-00	Bussmann 80FE	690V / 80A
11-201-43-425-00	Ferraz Shawmut A50QS100-4	500V / 100A
11-201-43-430-00	Bussmann 120FEE	690V / 120A
11-201-43-440-00	Ferraz Shawmut A50QS150-4	500V / 150A
11-201-43-450-00	Ferraz Shawmut A50QS200-4	500V / 200A
11-201-43-460-00	Ferraz Shawmut A50QS250-4	500V / 250A
11-201-43-475-00	Ferraz Shawmut A50QS300-4	500V / 300A
11-301-21-2P5-30	Bussmann 16CT	690V / 16A
11-301-21-201-30	Bussmann 20CT	690V / 20A
11-301-21-202-30	Bussmann 32FE	690V / 32A
11-301-21-203-30	Bussmann 50FE	690V / 50A
11-301-43-401-30	Bussmann 10CT	690V / 10A
11-301-43-402-30	Bussmann 16CT	690V / 16A
11-301-43-403-30	Bussmann 16CT	690V / 16A
11-301-43-405-30	Bussmann 20CT	690V / 20A
11-301-43-408-30	Bussmann 32FE	690V / 32A
11-301-43-410-30	Bussmann 40FE	690V / 40A
11-301-43-415-30	Bussmann 63FE	690V / 63A
11-301-43-420-30	Bussmann 71FE	690V / 71A
11-301-43-425-30	Bussmann 100FEa	690V / 100A
11-301-43-430-30	Bussmann 100FEa	690V / 100A
11-301-43-440-30	Ferraz Shawmut A50QS125-4	500V / 125A
11-301-43-450-30	Ferraz Shawmut A50QS175-4	500V / 175A
11-301-43-460-30	Ferraz Shawmut A50QS200-4	500V / 200A
11-301-43-476-30	Ferraz Shawmut A50QS300-4	500V / 300A

Préface

- ◆ Le produit est un lecteur conçu pour commander un moteur à induction triphasé. lire attentivement ce manuel pour garantir le bon fonctionnement, la sécurité et pour se familiariser avec les fonctions d'entraînement.
- ◆ Le lecteur est un appareil électrique / électronique et doit être installé et géré par un personnel qualifié
- ◆ Une mauvaise manipulation peut entraîner un fonctionnement incorrect, cycle de vie plus court, ou l'échec de ce produit ainsi que le moteur.
- ◆ Tous les documents sont sujets à changement sans préavis. Soyez sûr d'obtenir les dernières éditions de l'utilisation ou visitez notre site Web
- ◆ Lire le manuel d'instructions avant de procéder à l'installation, les connexions (câblage), le fonctionnement ou l'entretien et l'inspection.
- ◆ Vérifiez que vous avez une bonne connaissance de l'entraînement et de vous familiariser avec les consignes de sécurité et les précautions avant de procéder à fonctionner le lecteur.
- ◆ prêter attention aux consignes de sécurité indiquées par l'avertissement  et symbole Attention .

Avertissement

ignorer les informations indiquées par le symbole d'avertissement peut entraîner la mort ou des blessures graves.

Attention

ignorer les informations indiquées par le symbole de mise en garde peut entraîner des blessures mineures ou modérées et / ou des dommages matériels importants.

Chapitre 1 Consignes de sécurité

1.1 avant d'alimenter le disque dur

Avertissement

- Le circuit principal doit être correctement câblée. Pour les terminaux monophasés d'approvisionnement de l'utilisation des intrants (R/L1, T/L3) et de trois bornes d'entrée de l'utilisation de l'offre de phase (R/L1, S/L2, T/L3). U/T1, V/T2, W/T3 ne doivent être utilisés pour connecter le moteur. Raccordement de l'alimentation d'entrée à l'un des U/T1, V/T2 W/T3 ou bornes risque d'endommager le lecteur.

Attention

- Pour éviter que le couvercle ne se désengage ou de tout autre dommage physique, ne portez pas le lecteur par son couverture. Soutenir le groupe par son dissipateur de chaleur lors du transport. Une mauvaise manipulation peut endommager le lecteur ou blesser le personnel, et doit être évitée.
- Pour éviter que les risques d'incendie, ne pas installer le lecteur sur ou à proximité d'objets inflammables. Installer sur des objets ininflammables comme les surfaces métalliques.
- Si plusieurs disques sont placés dans le même panneau de contrôle, fournir une ventilation adéquate pour maintenir la température en dessous de 40 ° C/104 ° F (50 ° C/122 ° F sans housse de protection) pour éviter la surchauffe ou incendie. Lors d'un retrait ou d'installation de l'opérateur numérique, éteignez-le d'abord, puis de suivre les instructions de ce manuel pour éviter les erreurs de l'opérateur ou de la perte de l'affichage causé par des connexions défectueuses.

Avertissement

- Lors d'un retrait ou d'installation de l'opérateur numérique, éteignez-le d'abord, puis de suivre les instructions de ce manuel pour éviter les erreurs de l'opérateur ou de la perte de l'affichage causé par des connexions défectueuses....

1.2 Câblage

Avertissement

- Coupez toujours l'alimentation électrique avant de procéder à l'installation d'entraînement et le câblage des terminaux utilisateurs.

- Le câblage doit être effectué par un personnel qualifié / électricien certifié.
- Assurez-vous que le lecteur est correctement mis à la terre. (220V Classe: impédance de mise à la terre doit être inférieure à 100Ω Classe 440V: Impédance de mise à la terre doit être inférieure à 10Ω.)
- vérifier et tester mes circuits d'arrêt d'urgence après le câblage. (L'Installateur est responsable du câblage.)
- Ne touchez jamais de l'entrée ou de lignes électriques de sortie permettant directement ou toute entrée ou de lignes de puissance de sortie à venir en contact avec le boîtier d'entraînement.
- Ne pas effectuer un test de tenue en tension diélectrique (mégohmmètre) sur le disque dur ou cela va entraîner des dommages de lecture pour les composants semi-conducteurs.

 **Attention**

- La tension d'alimentation appliquée doit se conformer à la tension d'entrée spécifiée par le lecteur. (Voir la section signalétique du produit)
- Raccorder la résistance de freinage et de l'unité de freinage sur les bornes assignées.
- Ne pas brancher une résistance de freinage directement sur les bornes CC P (+) et N (-), sinon risque d'incendie.
- Utilisez des recommandations de la jauge de fil et les spécifications de couple. (Voir Wire Gauge et la section de spécification de couple) °
- Ne jamais brancher l'alimentation d'entrée aux bornes onduleur de sortie U/T1, V/T2, W/T3.
- Ne pas brancher un contacteur ou interrupteur en série avec le variateur et le moteur.
- Ne branchez pas un facteur condensateur de correction de puissance ou supprimeur de tension à la sortie du variateur °
- S'assurer que l'interférence générée par l'entraînement et le moteur n'a pas d'incidence sur les périphériques.

1.3 Avant l'opération

 **Avertissement**

- Assurez-vous que la capacité du disque correspond aux paramètres de notation avant d'alimenter.
- Réduire le paramètre de la fréquence porteuse si le câble du variateur au moteur est supérieure à 80 pi (25 m). Un courant de haute fréquence peut être générée par la capacité parasite entre les câbles et entraîner un déclenchement de surintensité du variateur, une augmentation du courant ou d'une lecture actuelle inexacts.
- Veillez à installer tous les couvercles avant de l'allumer. Ne retirez pas les capots pendant que l'alimentation du lecteur est allumé, un choc électrique peut se produire autrement.
- Ne pas actionner d'interrupteurs avec les mains mouillées, un choc électrique pourrait survenir autrement.
- Ne touchez pas les bornes d'entraînement lorsqu'il est alimenté, même si le lecteur est arrêté, un choc électrique pourrait survenir autrement.

1.4 Configuration Paramètre

 **Attention**

- Ne branchez pas une charge pour le moteur tout en effectuant un auto-tune.
- Assurez-vous que le moteur peut fonctionner librement et il y a suffisamment d'espace autour du moteur lors de l'exécution d'un auto-tune rotation.

1.5 Opération

 **Avertissement**

- Veillez à installer tous les couvercles avant de l'allumer. Ne retirez pas les capots pendant que l'alimentation du lecteur est allumé, un choc électrique peut se produire autrement.
- Ne pas brancher ou débrancher le moteur pendant le fonctionnement. Le variateur pourrai se déclencher et ainsi endommager le lecteur.
- Les opérations peuvent commencer soudainement si une alarme ou un défaut est

réarmé avec un ordre de marche active. Assurez-vous qu'un ordre de marche est actif lors de la réinitialisation de l'alarme ou de défaut, autrement des accidents peuvent se produire.

- Ne pas actionner d'interrupteurs avec les mains mouillées, un choc électrique pourrait survenir .
- Un interrupteur d'urgence externe indépendant est fourni, qui s'arrête en urgence vers le bas la sortie de l'onduleur en cas de danger.
- Si le redémarrage automatique après une récupération d'énergie est activée, le variateur démarrera automatiquement après le rétablissement du courant.
- Assurez-vous qu'il est sûr de faire fonctionner le variateur et le moteur avant d'effectuer un auto-tune rotation.
- Ne touchez pas les bornes d'entraînement lorsqu'il est alimenté même si l'onduleur s'est arrêté, un choc électrique pourrait survenir .
- Ne pas contrôler les signaux sur les circuits pendant que le lecteur est en marche.
- Après la mise hors tension, le ventilateur de refroidissement peut continuer à fonctionner pendant un certain temps.

 Attention

- Ne touchez pas les composants générant de la chaleur tels que radiateurs et des résistances de freinage. 
- Vérifiez soigneusement la performance du moteur ou de la machine avant d'utiliser à grande vitesse, sous peine de blessure.
- Notez les réglages des paramètres liés à l'unité de freinage lorsque applicable.
- Ne pas utiliser la fonction de freinage d'entraînement pour un maintien mécanique, sous peine de blessure.
- Ne pas contrôler les signaux sur les circuits pendant que le lecteur est en marche.

1.6 Entretien, Inspection et remplacement

 Avertissement

- Attendre un minimum de 5 minutes après que l'alimentation a été débranchée avant de commencer une inspection. Vérifiez également que le voyant de charge est éteint et que la tension du bus cc a chuté au-dessous de 25Vdc.
- Ne jamais toucher les bornes à haute tension dans le lecteur.
- Assurez-vous que l'alimentation du lecteur est débranché avant de démonter le lecteur.
- Seul le personnel autorisé peuvent faire l'entretien, l'inspection et les opérations de remplacement. (Enlevez les bijoux en métal tels que les montres et les bagues et utiliser des outils isolés.)

 Attention

- Le variateur peut être utilisé dans un environnement avec une gamme de température allant de 14 ° -104 ° F (10-40 ° C) et l'humidité relative de 95% sans condensation.
- Le variateur doit être utilisé dans un environnement sans poussière, gaz, vapeur et humidité.

1.7 Mise au rebut du variateur

 Attention

- jeter cet appareil avec soin comme un déchet industriel et selon les réglementations locales nécessaires.
- Les condensateurs du circuit principal d'entraînement et circuits imprimés sont considérés comme des déchets dangereux et ne doivent pas être brûlés.
- The Plastic enclosure and parts of the drive such as the top cover board will release harmful gases if burned.



Les équipements contenant des composants électriques ne doivent pas être jetés avec les ordures ménagères. Il doit être collecté séparément avec les déchets électriques et électroniques conformément à la législation locale en vigueur.

產品說明書附件

產品中的有害物質的名稱及含量

部件名稱		有毒有害物質或元素					
		鉛及其化合物 (Pb)	汞及其化合物 (Hg)	鎘及其化合物 (Cd)	六價鉻化合物 (Cr(VI))	多溴聯苯 (PBB)	多溴二苯醚 (PBDE)
電子部件	電子元器件	X	O	O	O	O	O
	電磁接觸器	O	O	X	O	O	O
顯示器		O	O	O	O	O	O
電線和電纜	接線端子	X	O	O	O	O	O
	導線	O	O	O	O	O	O
	絕緣部件	O	O	O	O	O	O
機械部件	導電銅柱、風扇、 溫控開關	X	O	O	O	O	O
	其他	O	O	O	O	O	O

本表格依據 SJ/T 11364 的規定編制。

O: 表示該有毒有害物質在該部件所有均質材料中的含量均在 GB/T 26572 規定的限量要求以下。

X: 表示該有毒有害物質至少在該部件的某一均質材料中的含量超出 GB/T 26572 標準規定的限量要求。

主要部件名稱中的部件定義：

電子部件 - 包括電子元件、焊接印刷電路板等。

顯示器 - 包括顯示單元、電子元器件或觸控式螢幕。

電線和電纜 - 包括終端、接線、遮罩線、護套以及電子部件。

機械部件 - 除已定義電子部件、顯示器、電線和電纜以外的部件。

超限說明：

電子元器件：部分電子元器件中鉛含量超過 1000ppm 但符合歐盟 RoHS 指令豁免條例

7 (a)：高熔融溫度型焊料中的鉛（例如：鉛基合金中鉛含量 \geq 85 %）；

7 (c) -I：電子器件的玻璃或陶瓷（電容中介電陶瓷除外）中的鉛，或玻璃或陶瓷複合材料中的鉛（例如：壓電陶瓷器件）

電磁接觸器：部分電磁接觸器中鎘含量超過 100ppm 符合歐盟 RoHS 指令豁免條例

8 (b) 鎘及其化合物，用於電子觸點。

接線端子、導電銅柱、風扇、溫控開關：電線和電纜、機械部件中某些組成部分可能鉛含量超過 1000ppm 但符合歐盟 RoHS 指令豁免條例

6 (a) 鉛作為一種合金元素，在用於加工的鋼和鍍鋅鋼中鉛含量不超過 0.35% (Wt)；

6 (b) 鋁合金中的鉛含量最大容許濃度為 0.4%；

6 (c) 銅合金中的鉛含量最大容許濃度為 4%；

環保使用期限說明：

在環保使用期限內，消費者在正常使用過程中，本產品不會出現有害物質洩漏，析出等影響消費者健康的問題，可以放心使用。

本公司產品環保使用期限為 10 年，只有在本說明書所述的正常情況下使用本產品時，“環保使用期限”才有效。 

免責聲明：由本公司所提供的關於其產品中所含物質含量的資訊，僅代表本公司在提供該資訊之時對該產品的瞭解和知識。本公司的這些知識和瞭解是基於由協力廠商提供的資訊為基礎的，而本公司無法承諾也無法保證該等協力廠商資訊的準確性。本公司可能沒有就所採用的材料或化學品進行破壞性測試或化學分析。上述產品的使用和本公司的相關責任，應以本公司的標準合同條款為準。



Manufacturer's Statement for E510s series

E510s efficiency according to IEC/EN 61800-9-2

Drive models: E510s series, please refer to the table below for the model list

Efficiency class: IE2

Nominal voltage: Please refer to the tabel below

Nominal frequency: 50Hz

Nominal power: Please refer to the tabel below

Motor control: V/f, Sensorless vector,

PM sensorless vector

Nominal current: Please refer to the table below

Nominal apparent power: Please refer to the table below

Maximum operating temperature:

IP20: 50°C without dustproof sticker

40°C with dustproof sticker

IP66: 40°C

CDM losses and efficiency (calculated with default settings) point: As the picture right

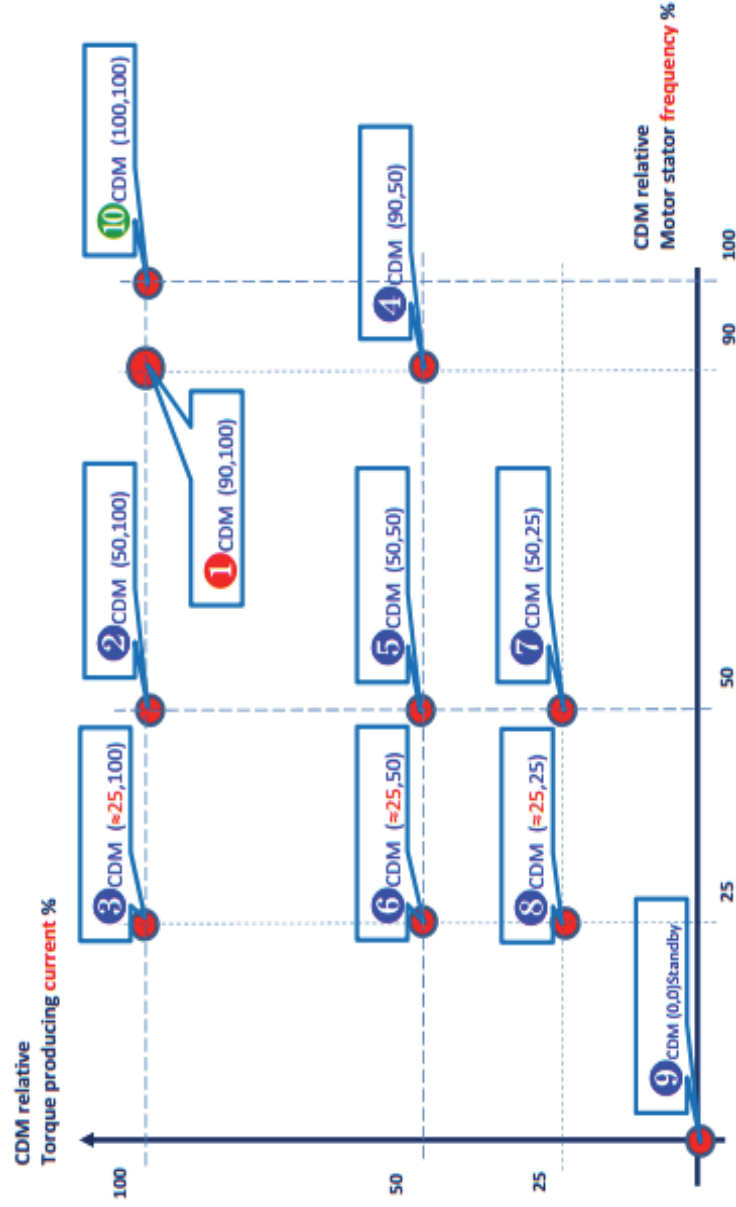

Manufacturer: TECO Electric & Machinery CO., LTD. — 10F, No.3-1, Park St., Nan-Kang, Taipei, 115603, Taiwan

EU contact: MOTOVARIO S.p.A — Via Quattro Passi 1/3 — 41043 — Formigine (MO) — ITALY. MOTOVARIO EORI number: IT02569681204

CDM losses and efficiency table

Frame Model Name	Nominal voltage (V)	Nominal current (A)	Nominal power (kW)	Nominal apparent power (kVA)	④ CDM (25,25) or (*12Hz,25)		⑤ CDM(25;50) or (*12Hz,50)		⑥ CDM(25; 100) or (*12Hz,100)		⑦ CDM (50,25)		⑧ CDM (50,50)		⑨ CDM (50,100)		⑩ CDM (90,50)		⑪ CDM (90,100)		⑫ CDM (100,100)		
					p Loss(W)	η(%)	p Loss(W)	η(%)	p Loss(W)	η(%)	p Loss(W)	η(%)	p Loss(W)	η(%)	p Loss(W)	η(%)	p Loss(W)	η(%)	p Loss(W)	η(%)	p Loss(W)	η(%)	p Loss(W)
IP20 220V with Filter																							
1	E510-2P5-SH1F	220	3.1	0.4	1.2	23	70.3	23	78.1	27	84.5	23	82.9	24	87.9	27	91.6	25	92.6	29	94.8	30	95.2
1	E510-201-SH1F	220	4.5	0.75	1.7	32	74.6	37	83.1	48	87.4	32	85.7	38	90.7	51	93.1	41	94.2	57	95.5	59	95.8
2	E510-202-SH1F	220	7.5	1.5	2.9	50	75.5	58	83.6	76	87.7	51	86.1	61	90.9	83	93.2	67	94.2	97	95.4	101	95.7
2	E510-203-SH1F	220	10.5	2.2	4	63	77.3	75	84.6	102	88.1	65	87.2	79	91.5	111	93.4	90	94.6	131	95.5	137	95.8
IP20 380V with Filter																							
1	E510-401-SH3F	380	2.5	0.75	1.7	28	77.7	32	83.4	39	88.1	28	85.8	32	91.1	41	93.7	33	94.6	46	95.9	47	96.4
1	E510-402-SH3F	380	3.8	1.5	2.9	38	78.1	44	85.5	58	89.1	38	88.0	45	92.3	60	94.2	47	95.3	65	96.4	66	96.7
2	E510-403-SH3F	380	5.3	2.2	4	52	78.0	60	85.5	79	89.2	53	87.9	62	92.2	82	94.2	65	95.3	88	96.4	90	96.7
2	E510-405-SH3F	380	9.2	4	6.7	71	79.6	89	86.3	130	89.4	73	88.9	93	92.7	135	94.4	101	95.6	146	96.5	149	96.8
3	E510-408-SH3F	380	13	5.5	9.9	79	86.7	94	90.9	137	92.7	80	92.9	97	95.2	147	96.1	102	97.0	168	97.4	174	97.6
3	E510-410-SH3F	380	17.5	7.5	13.3	111	84.8	139	89.5	220	91.4	113	91.9	144	94.4	231	95.4	153	96.6	254	97.1	260	97.3
3	E510-415-SH3F	380	24	11	19.1	146	85.7	189	89.9	312	91.4	150	92.4	197	94.6	330	95.4	211	96.7	365	97.1	376	97.3
4	E510-420-SH3F	380	32	15	24	175	86.5	229	90.4	381	91.8	181	92.8	240	94.9	408	95.6	262	96.8	464	97.1	481	97.3
4	E510-425-SH3F	380	40	18.5	30.5	203	87.4	266	91.0	447	92.3	209	93.3	280	95.2	482	95.8	309	97.0	560	97.2	584	97.4
5	E510-430-SH3F	380	45	22	34.3	259	89.9	333	91.4	487	93.3	299	94.3	364	95.3	555	96.1	338	97.5	605	97.5	605	97.8
6	E510-440-SH3F	380	60	30	45.7	324	89.9	421	91.4	621	93.3	353	94.5	431	95.5	690	96.3	396	97.6	740	97.6	740	97.8
6	E510-450-SH3F	380	75	37	57.2	414	89.5	538	91.0	860	92.9	520	93.3	682	94.3	1190	95.1	622	97.0	1350	97.0	1350	97.4
6	E510-460-SH3F	380	91	45	69.3	524	89.6	700	91.1	1069	93.0	692	93.4	896	94.4	1380	95.1	786	97.1	1480	97.1	1480	97.5
6	E510-475-SH3F	380	118	55	89.9	679	89.8	902	91.3	1366	93.2	846	93.8	1081	94.8	1630	95.6	985	97.2	1650	97.3	1660	97.7
IP66 with Filter																							
1	E510-2P5-SH1FN4S	220	3.1	0.4	1.2	23	70.3	23	78.1	27	84.5	23	82.9	24	87.9	27	91.6	25	92.6	29	94.8	30	95.2
1	E510-201-SH1FN4S	220	4.5	0.75	1.7	32	74.6	37	83.1	48	87.4	32	85.7	38	90.7	51	93.1	41	94.2	57	95.5	59	95.8
2	E510-202-SH1FN4S	220	7.5	1.5	2.9	50	75.5	58	83.6	76	87.7	51	86.1	61	90.9	83	93.2	67	94.2	97	95.4	101	95.7
2	E510-203-SH1FN4S	220	10.5	2.2	4	63	77.3	75	84.6	102	88.1	65	87.2	79	91.5	111	93.4	90	94.6	131	95.5	137	95.8
1	E510-401-SH3FN4S	380	2.5	0.75	1.7	28	77.7	32	83.4	39	88.1	28	85.8	32	91.1	41	93.7	33	94.6	46	95.9	47	96.4
1	E510-402-SH3FN4S	380	3.8	1.5	2.9	38	78.1	44	85.5	58	89.1	38	88.0	45	92.3	60	94.2	47	95.3	65	96.4	66	96.7
2	E510-403-SH3FN4S	380	5.3	2.2	4	52	78.0	60	85.5	79	89.2	53	87.9	62	92.2	82	94.2	65	95.3	88	96.4	90	96.7
2	E510-405-SH3FN4S	380	9.2	4	6.7	71	79.6	89	86.3	130	89.4	73	88.9	93	92.7	135	94.4	101	95.6	146	96.5	149	96.8
3	E510-408-SH3FN4S	380	13	5.5	9.9	79	86.7	94	90.9	137	92.7	80	92.9	97	95.2	147	96.1	102	97.0	168	97.4	174	97.6
3	E510-410-SH3FN4S	380	17.5	7.5	13.3	111	84.8	139	89.5	220	91.4	113	91.9	144	94.4	231	95.4	153	96.6	254	97.1	260	97.3
3	E510-415-SH3FN4S	380	24	11	19.1	146	85.7	189	89.9	312	91.4	150	92.4	197	94.6	330	95.4	211	96.7	365	97.1	376	97.3

Frame	Model Name	Nominal voltage (V)	Nominal current (A)	Nominal power (kW)	Nominal apparent power (kVA)
IP20 380V without Filter					
1	E510-401-SH3	380	2.5	0.75	1.7
1	E510-402-SH3	380	3.8	1.5	2.9
2	E510-403-SH3	380	5.3	2.2	4
2	E510-405-SH3	380	9.2	4	6.7
3	E510-408-SH3	380	13	5.5	9.9
3	E510-410-SH3	380	17.5	7.5	13.3
3	E510-415-SH3	380	24	11	19.1
4	E510-420-SH3	380	32	15	24
4	E510-425-SH3	380	40	18.5	30.5
5	E510-430-SH3	380	45	22	34.3
6	E510-440-SH3	380	60	30	45.7
6	E510-450-SH3	380	75	37	57.2
6	E510-460-SH3	380	91	45	69.3
6	E510-475-SH3	380	118	55	89.9
IP66 380V without Filter					
1	E510-401-SH3N4	380	2.5	0.75	1.7
1	E510-402-SH3N4	380	3.8	1.5	2.9
2	E510-403-SH3N4	380	5.3	2.2	4
2	E510-405-SH3N4	380	9.2	4	6.7
3	E510-408-SH3N4	380	13	5.5	9.9
3	E510-410-SH3N4	380	17.5	7.5	13.3
3	E510-415-SH3N4	380	24	11	19.1
3	E510-420-SH3N4	380	32	15	24
3	E510-425-SH3N4	380	40	18.5	30.5
IP20 220V without Filter					
1	E510-2P-5-SH	220	3.1	0.4	1.2
1	E510-201-SH	220	4.5	0.75	1.7
2	E510-202-SH	220	7.5	1.5	2.9
2	E510-203-SH	220	10.5	2.2	4
1	E510-202-SH3	220	7.5	1.5	2.9
2	E510-205-SH3	220	17.5	4	6.7
3	E510-208-SH3	220	26	5.5	9.9
3	E510-210-SH3	220	35	7.5	13.3
4	E510-220-SH3	220	48	11	20.6
4	E510-215-SH3	220	64	15	27.4
5	E510-225-SH3	220	73	18.5	27.8
6	E510-230-SH3	220	85	22	32.4
6	E510-240-SH3	220	115	30	43.8
IP66 220V without Filter					
1	E510-2P-5-SH N4	220	3.1	0.4	1.2
1	E510-201-SH N4	220	4.5	0.75	1.7
2	E510-202-SH N4	220	7.5	1.5	2.9
2	E510-203-SH N4	220	10.5	2.2	4
3	E510-205-SH3 N4	220	17.5	4	6.7
3	E510-208-SH3 N4	220	26	5.5	9.9
3	E510-210-SH3 N4	220	35	7.5	13.3
3	E510-215-SH3 N4	220	48	11	20.6
3	E510-225-SH3 N4	220	73	18.5	27.8
3	E510-230-SH3 N4	220	85	22	32.4
3	E510-240-SH3 N4	220	115	30	43.8

CDM STANDBY LOSS	④ CDM (25,25) or (*12Hz,25)		⑤ CDM (50,25)		⑥ CDM (50,50)		⑦ CDM (50,100)		⑧ CDM (90,50)		⑨ CDM (90,100)		⑩ CDM (100,100)	
	p Loss(W)	η(%)	p Loss(W)	η(%)	p Loss(W)	η(%)	p Loss(W)	η(%)	p Loss(W)	η(%)	p Loss(W)	η(%)	p Loss(W)	η(%)
13	27	77.8	31	83.5	38	88.2	40	93.8	32	94.7	45	96.0	46	96.5
13	37	78.2	43	85.6	57	89.2	59	94.3	46	95.4	64	96.5	65	96.8
19	51	78.1	59	85.6	78	89.3	81	94.3	64	95.4	87	96.5	89	96.8
22	69	79.7	87	86.4	129	89.5	134	94.5	99	95.7	145	96.6	148	96.9
22	78	86.8	93	91.0	135	92.8	145	96.2	101	97.1	166	97.5	172	97.7
32	109	84.9	137	89.6	218	91.5	229	95.5	151	96.7	252	97.2	258	97.4
32	144	85.8	187	90.0	310	91.5	328	95.5	209	96.8	363	97.2	374	97.4
34	172	86.6	226	90.5	378	91.9	409	95.7	259	96.9	461	97.2	478	97.4
34	200	87.5	263	91.1	444	92.4	479	95.9	306	97.1	557	97.3	581	97.5
34	261	89.9	337	91.3	494	93.2	550	96.0	352	97.4	600	97.4	600	97.7
39	327	89.9	426	91.3	631	93.2	685	96.2	413	97.5	735	97.5	735	97.7
39	414	89.5	558	91.0	860	92.9	933	95.2	622	97.0	1345	97.0	1345	97.4
39	524	89.6	700	91.1	1069	93.0	1185	95.2	758	97.2	1475	97.2	1475	97.5
39	679	89.8	902	91.3	1366	93.2	1625	95.7	949	97.3	1645	97.4	1655	97.7
13	27	77.8	31	83.5	38	88.2	40	93.8	32	94.7	45	96.0	46	96.5
13	37	78.2	43	85.6	57	89.2	59	94.3	46	95.4	64	96.5	65	96.8
19	51	78.1	59	85.6	78	89.3	81	94.3	64	95.4	87	96.5	89	96.8
22	69	79.7	87	86.4	129	89.5	134	94.5	99	95.7	145	96.6	148	96.9
22	78	86.8	93	91.0	135	92.8	145	96.2	101	97.1	172	97.2	187	97.7
32	109	84.9	137	89.6	218	91.5	229	95.5	151	96.7	252	97.2	258	97.4
32	144	85.8	187	90.0	310	91.5	328	95.5	209	96.8	359	94.9	374	97.4
34	172	86.6	226	90.5	378	91.9	409	95.7	259	96.9	461	97.22	478	97.4
34	200	87.5	263	91.1	444	92.4	479	95.9	306	97.1	557	97.31	581	97.5
10	22	70.4	22	78.2	26	84.6	26	91.7	24	92.7	28	94.9	29	95.3
13	31	74.7	36	83.2	47	87.5	50	93.2	40	94.3	56	95.6	58	95.9
19	49	75.6	57	83.7	75	87.8	82	93.3	66	94.3	81	96.2	100	95.8
19	62	77.4	74	84.7	101	88.2	110	93.5	89	94.7	130	95.6	136	95.9
13	45	77.0	54	84.5	74	88.0	78	93.5	59	94.9	86	96.0	88	96.3
20	91	79.6	110	86.1	158	88.9	172	93.9	131	95.1	205	95.9	215	96.1
30	102	83.7	129	88.7	203	90.9	220	95.0	149	96.3	259	96.7	271	96.9
30	127	84.8	165	89.2	273	90.9	303	94.9	202	96.2	371	96.5	392	96.7
30	167	85.3	222	89.4	381	90.7	425	94.8	275	96.2	525	96.4	556	96.6
31	236	84.5	321	88.6	563	89.8	648	94.1	426	95.7	832	95.7	888	95.9
32	405	84.3	436	88.5	617	91.2	692	94.4	465	96.2	850	96.3	900	96.7
35	472	84.7	500	88.9	696	91.7	855	94.7	504	96.6	965	96.7	975	97.1
35	646	84.9	678	89.1	934	91.9	1035	95.2	656	96.8	1095	96.9	1125	97.0
10	22	70.4	22	78.2	26	84.6	26	91.7	24	92.7	28	94.9	29	95.3
13	31	74.7	36	83.2	47	87.5	50	93.2	40	94.3	56	95.6	58	95.9
19	49	75.6	57	83.7	75	87.8	82	93.3	66	94.3	81	96.2	100	95.8
19	62	77.4	74	84.7	101	88.2	110	93.5	89	94.7	130	95.6	136	95.9
20	91	79.6	110	86.1	158	88.9	172	93.9	131	95.1	205	95.9	215	96.1
30	102	83.7	129	88.7	203	90.9	220	95.0	149	96.3	259	96.7	271	96.9
30	127	84.8	165	89.2	273	90.9	303	94.9	202	96.2	371	96.5	392	96.7
30	167	85.3	222	89.4	381	90.7	425	94.8	275	96.2	525	96.4	556	96.6
31	236	84.5	321	88.6	563	89.8	648	94.1	426	95.7	832	95.7	888	95.9
32	405	84.3	436	88.5	617	91.2	692	94.4	465	96.2	850	96.3	900	96.7
35	472	84.7	500	88.9	696	91.7	855	94.7	504	96.6	965	96.7	975	97.1
35	646	84.9	678	89.1	934	91.9	1035	95.2	656	96.8	1095	96.9	1125	97.0
10	22	70.4	22	78.2	26	84.6	26	91.7	24	92.7	28	94.9	29	95.3
13	31	74.7	36	83.2	47	87.5	50	93.2	40	94.3	56	95.6	58	95.9
19	49	75.6	57	83.7	75	87.8	82	93.3	66	94.3	81	96.2	100	95.8
19	62	77.4	74	84.7	101	88.2	110	93.5	89	94.7	130	95.6	136	95.9
20	91	79.6	110	86.1	158	88.9	172	93.9	131	95.1	205	95.9	215	96.1
30	102	83.7	129	88.7	203	90.9	220	95.0	149	96.3	259	96.7	271	96.9
30	127	84.8	165	89.2	273	90.9	303	94.9	202	96.2	371	96.5	392	96.7
30	167	85.3	222	89.4	381	90.7	425	94.8	275	96.2	525	96.4	556	96.6
31	236	84.5	321	88.6	563	89.8	648	94.1	426	95.7	832	95.7	888	95.9
32	405	84.3	436	88.5	617	91.2	692	94.4	465	96.2	850	96.3	900	96.7
35	472	84.7	500	88.9	696	91.7	855	94.7	504	96.6	965	96.7	975	97.1
35	646	84.9	678	89.1	934	91.9								

东元电机授权代理经销商

唯马电机（上海）有限公司

 总部：上海市松江区梅家浜路800弄双高世贸广场1211-1213室

 sales@weimaelectric.com

 021-34050660

 www.weimaelectric.com



4KA72X564T51 Ver:06 2021.08